

# ROSA 2

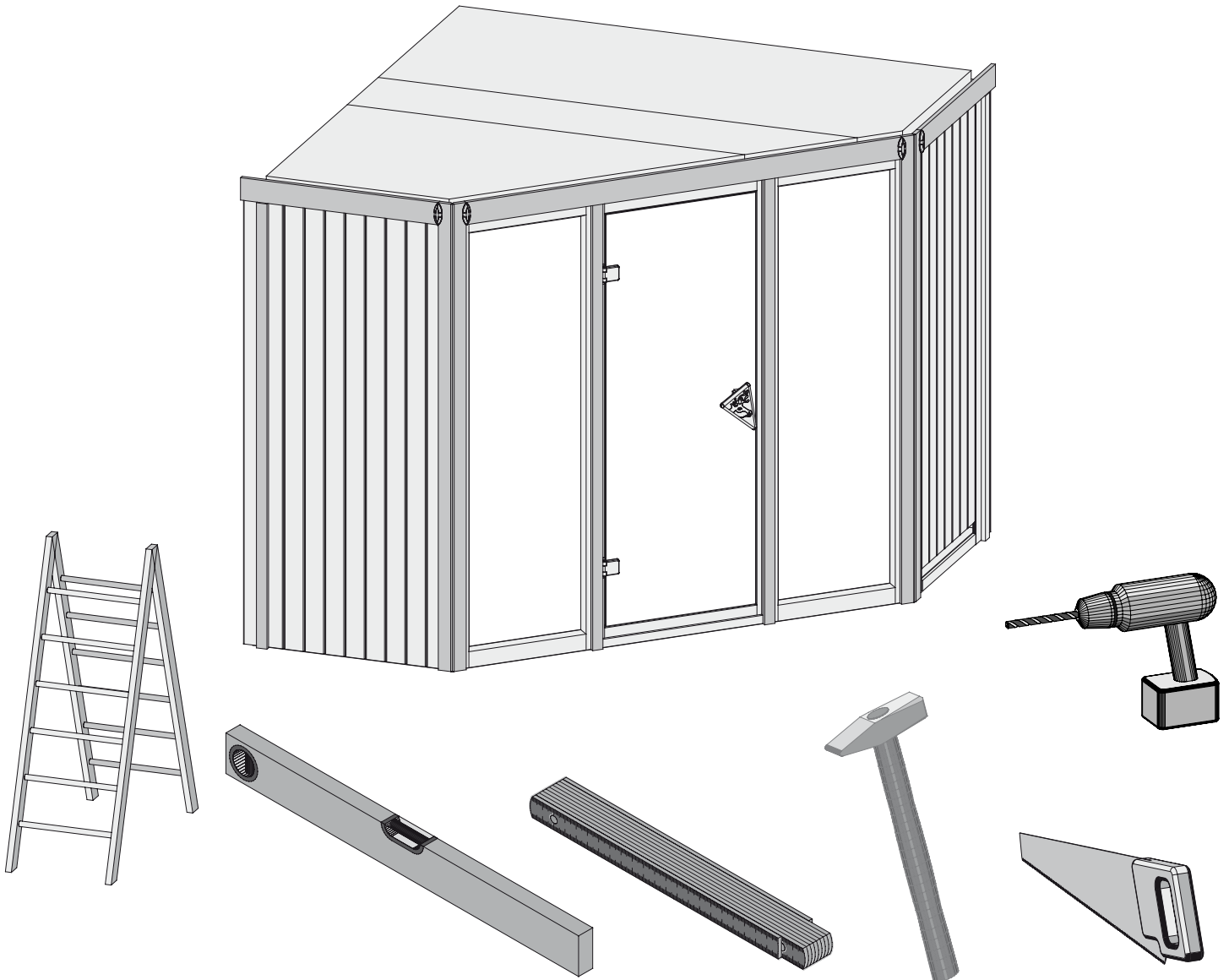

 **Aufbauanleitung**

 **notice de montage**

 **Building Instructions**

 **montagehandleiding**

 **Instrucciones de construcción**

 **Istruzioni per il montaggio**



Vergleichen Sie zuerst die Materialliste mit Ihrem Paketinhalt! Bitte haben Sie Verständnis, dass Beanstandungen nur im nicht aufgebauten Zustand bearbeitet werden können!



Commencez par comparer la liste du matériel avec le contenu de votre paquet! Sachez que nous traitons uniquement les réclamations concernant le matériel à l'état non monté!



First compare the list of materials with your package contents! Please understand that complaints can be processed in the non-built status only!



Vergelijk eerst de lijst van materialen met de inhoud van uw pakket! Reclamaties kunnen alleen in behandeling worden genomen zolang de onderdelen nog niet zijn gemonteerd!



En primer lugar, compare la lista de material con el contenido del paquete. Rogamos entienda que las reclamaciones sólo pueden ser tramitadas antes de montar el objeto!



Confrontate questa distinta materiali prima con il contenuto del pacchetto! Vi preghiamo di comprendere che eventuali reclami possono essere accolti solo prima del montaggio!



**52695 53242**

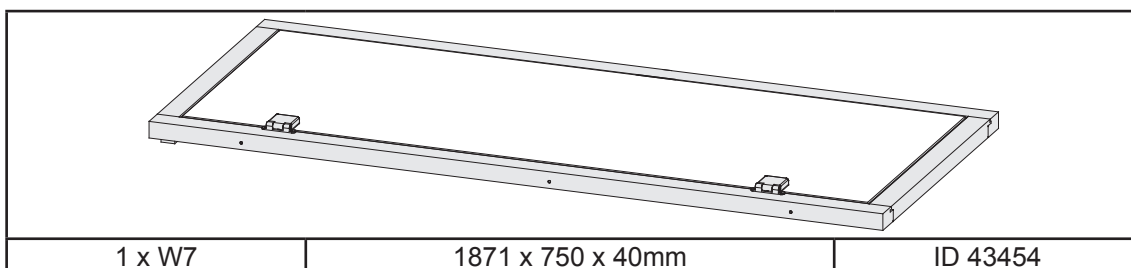
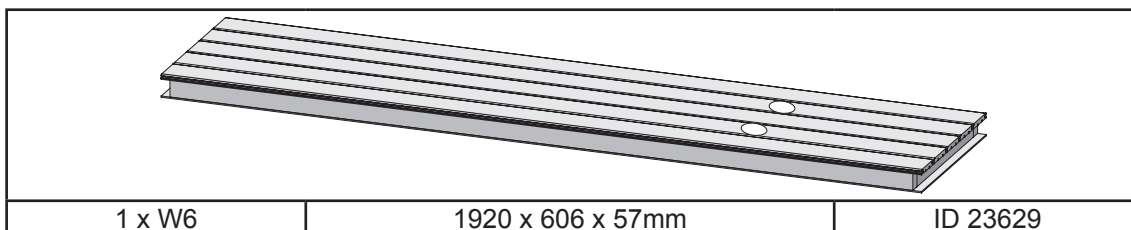
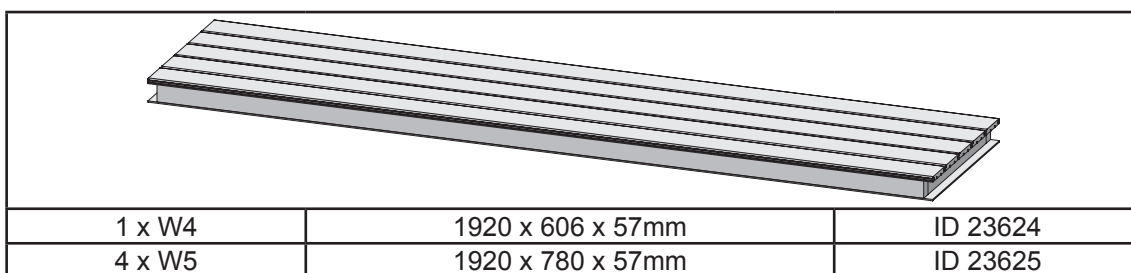
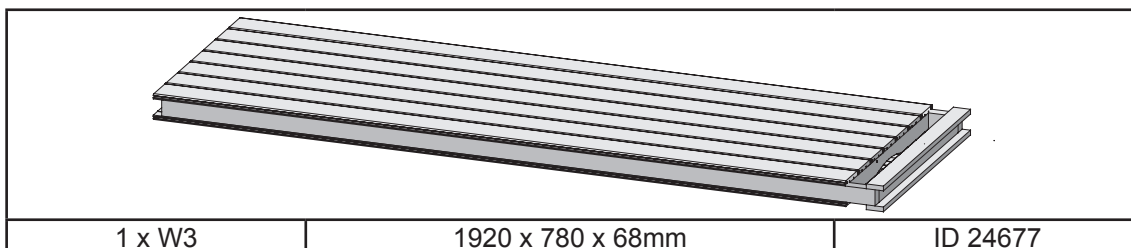
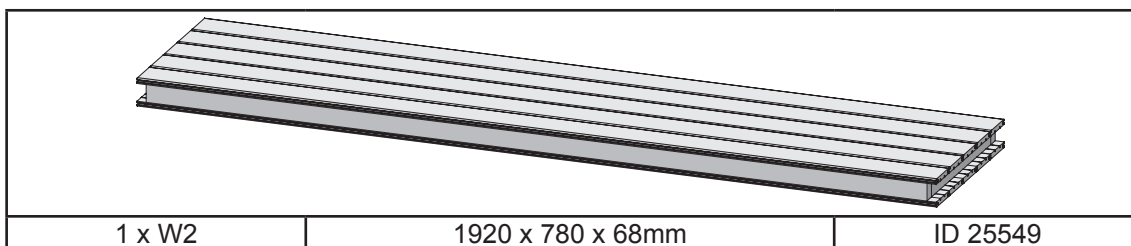
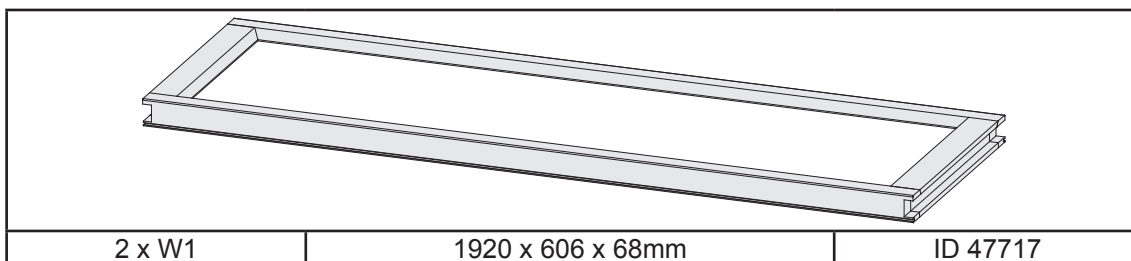

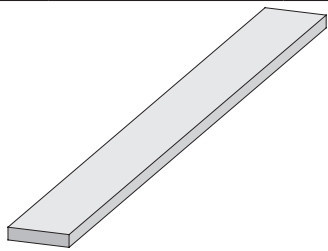

6 x B1	1920 x 19 x 3mm	ID 20799
2 x B2	1920 x 20 x 12mm	ID 52812
4 x B3	750 x 35 x 12mm	ID 24239
4 x B4	800 x 45 x 18mm	ID 24796
4 x B5	1884 x 45 x 18mm	ID 48037
4 x B6	480 x 95 x 18mm	ID 20930
4 x B7	580 x 95 x 18mm	ID 16708
2 x B8	845 x 95 x 18mm	ID 52651
1 x B9	1912 x 95 x 18mm	ID 52650
1 x B10	300 x 120 x 18mm	ID 22467
2 x B11	590 x 42 x 28mm	ID 26360
1 x B12	2110 x 42 x 28mm	ID 43453
1 x B13	2160 x 42 x 28mm	ID 24529
2 x B14	2187 x 42 x 28mm	ID 24534
2 x B15	2271 x 42 x 28mm	ID 36179
3 x B16	1874 x 52 x 52mm	ID 26165

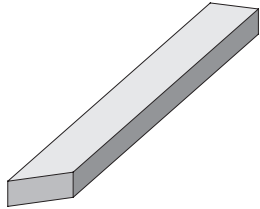

1 x C1	747 x 42 x 28mm	ID 56491
1 x C2	774 x 42 x 28mm	ID 56490
2 x C3	810 x 42 x 28mm	ID 56632
2 x C4	852 x 42 x 28mm	ID 24111

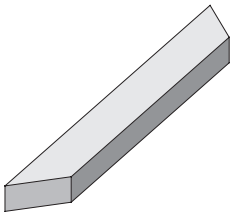

2 x D1	2007 x 42 x 28mm	ID 56634
1 x D2	1960 x 42 x 28mm	ID 56635

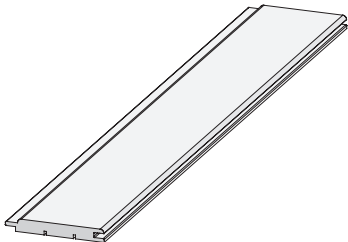

2 x E1	1920 x 97 x 12mm	ID 22863
--------	------------------	----------

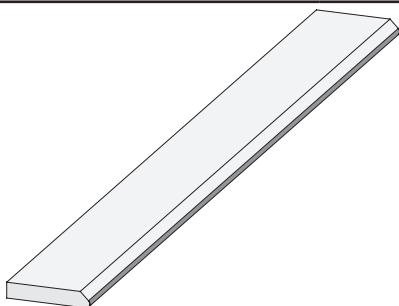

4 x E2	1980 x 58 x 17mm	ID 52813
--------	------------------	----------

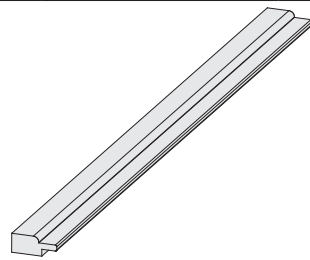

4 x E3	1920 x 30 x 12mm	ID 24237
--------	------------------	----------

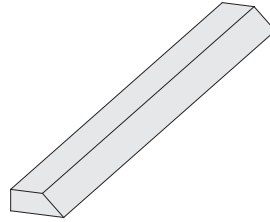

2 x E4	1884 x 45 x 17mm	ID 48538
--------	------------------	----------

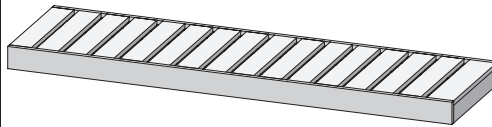

1 x L1	1058 x 500 x 90mm	ID 43550
1 x L2	1810 x 550 x 90mm	ID 21767
1 x L3	2156 x 550 x 90mm	ID 21768

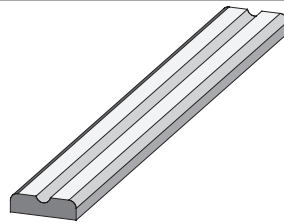

1 x L4	1058 x 90 x 22mm	ID 56637
1 x L5	1656 x 90 x 22mm	ID 56638
1 x L6	1810 x 90 x 22mm	ID 26112

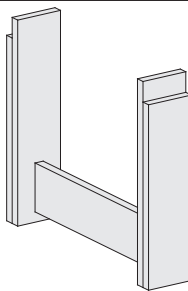

2 x N1	495 x 400 x 95mm	ID 30488
--------	------------------	----------

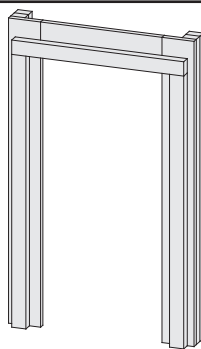

1 x N2		ID 52816
--------	--	----------

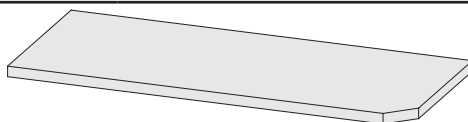

1 x M1	2187 x 918 x 57mm	ID 24539
--------	-------------------	----------

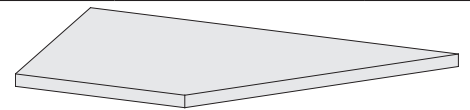

1 x M2	2049 x 349 x 57mm	ID 25771
1 x M3	1699 x 918 x 57mm	ID 25767

1 x

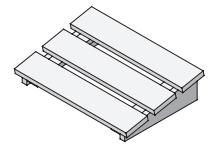

ID 25545



90 x	4 x 30mm	ID 3686
40 x	4 x 50mm	ID 3688
30 x	4 x 70mm	ID 3689
50 x	4,5 x 80mm	ID 9204
10 x	6 x 60mm	ID 14014



10 x	4,5 x 30mm	ID 26115
70 x	4,5 x 40mm	ID 26285

6 x S1



ID 14266

3 x



ID 42172



70 x S2	4,5 x 30mm	ID 26116
6 x S3	12 x 18mm	ID 46403

4 x T1



ID 26272

10 x



ID 14005

10m

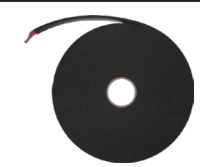

ID 14025

1 x



ID 26114

2 x

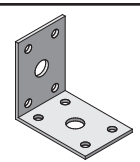

ID 21292

2 x

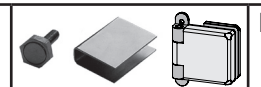

ID 26496

1 x

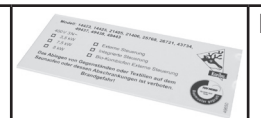

ID 49868

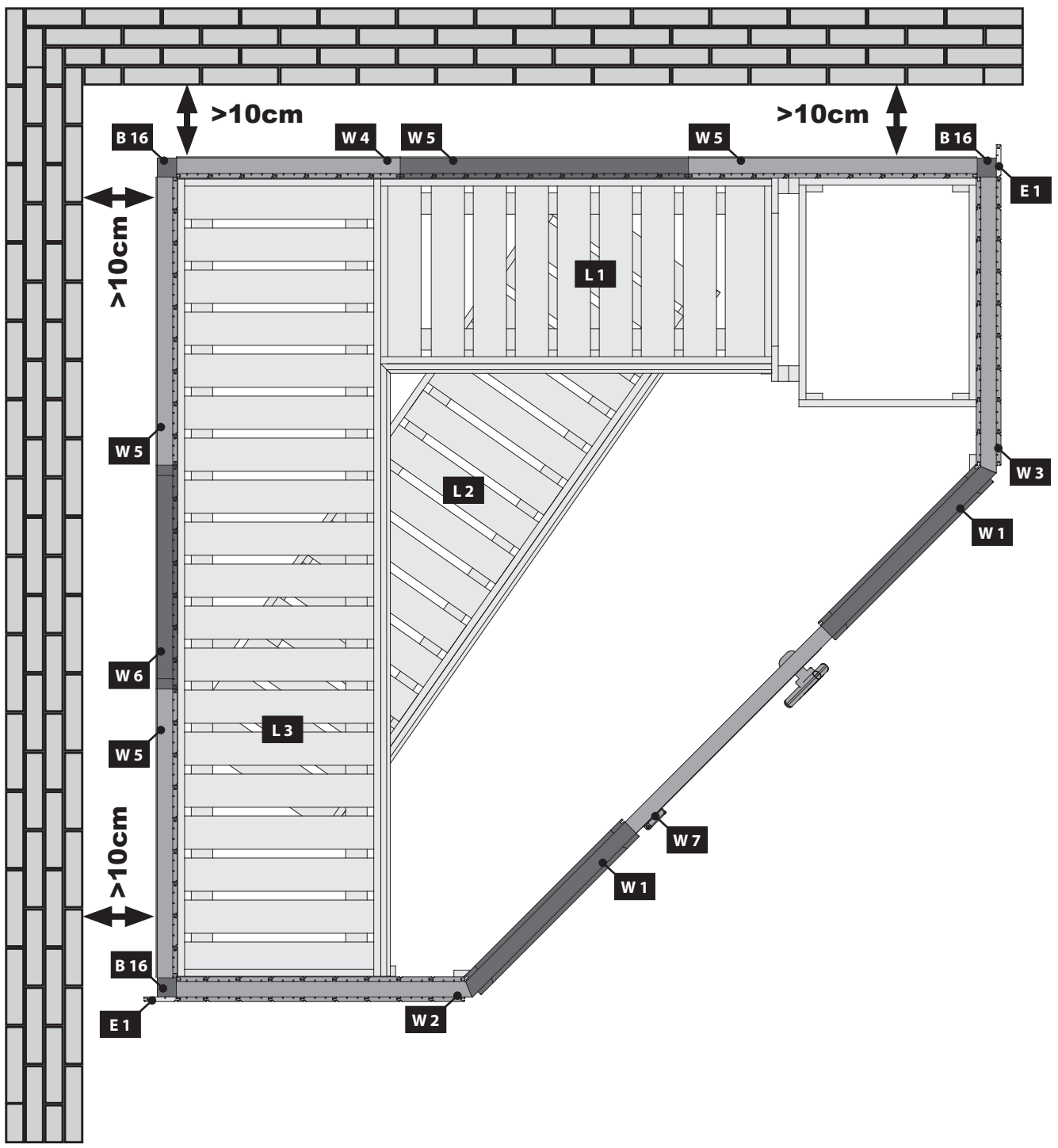



02 2x

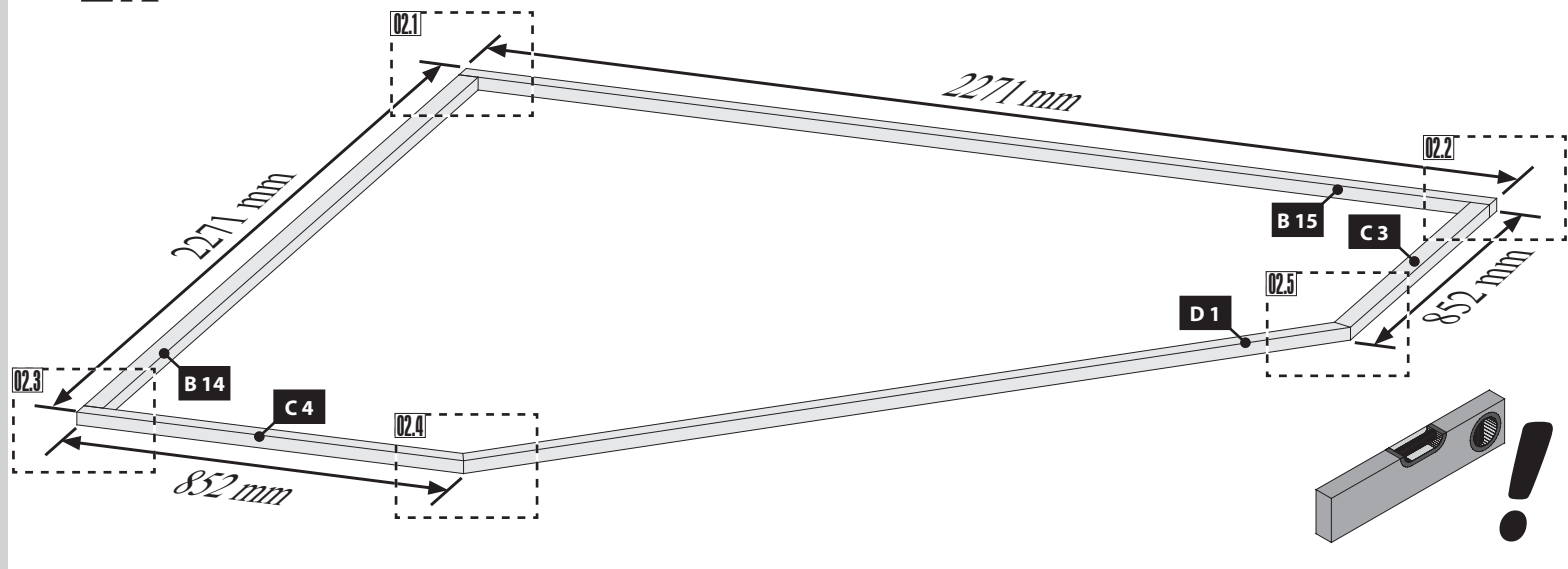

02.1

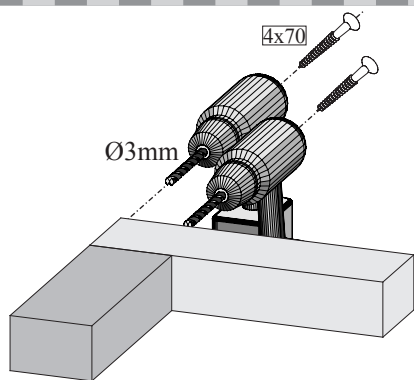

02.2

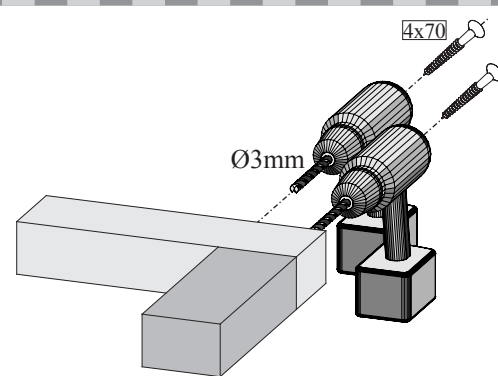

02.3

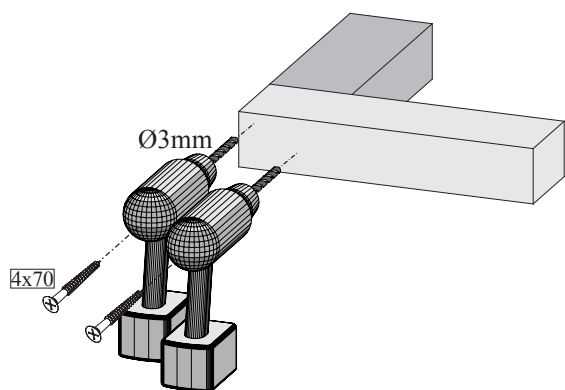

02.4

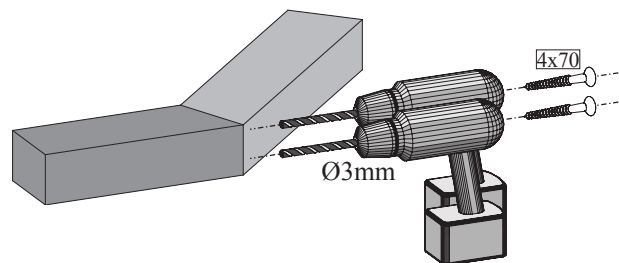

02.5

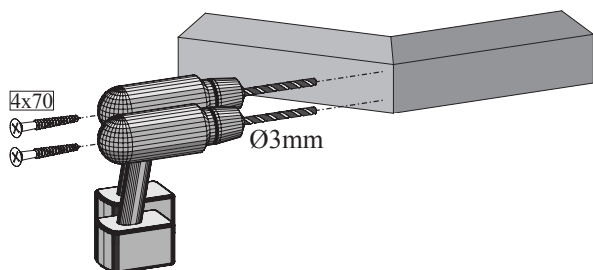

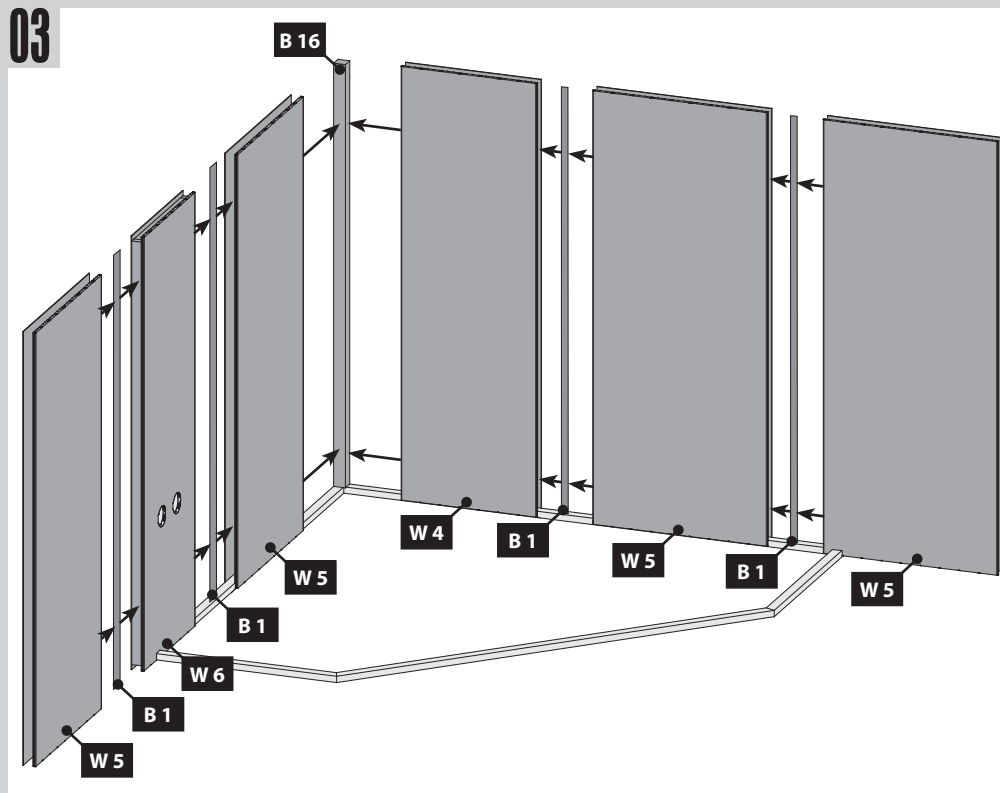
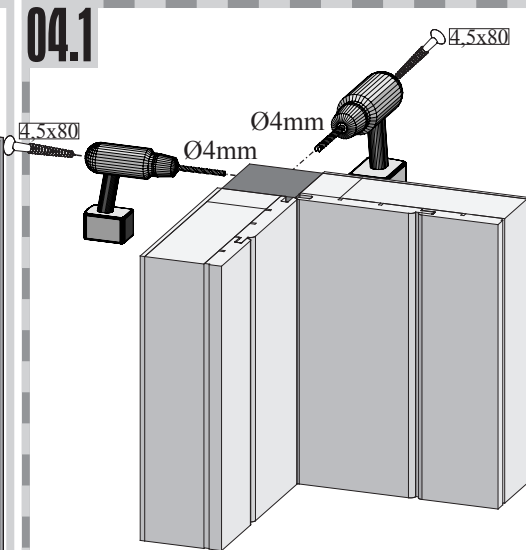
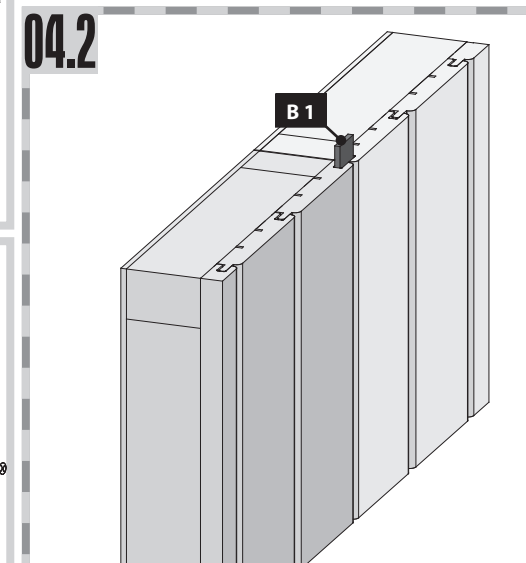
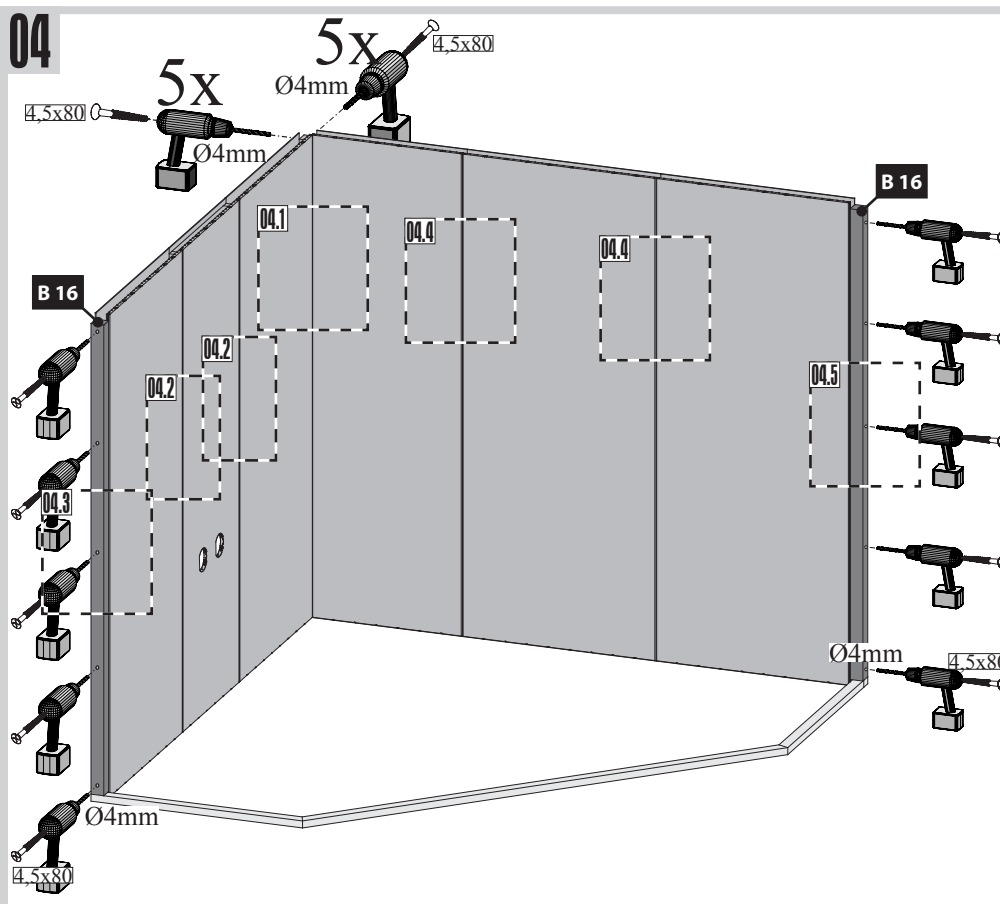
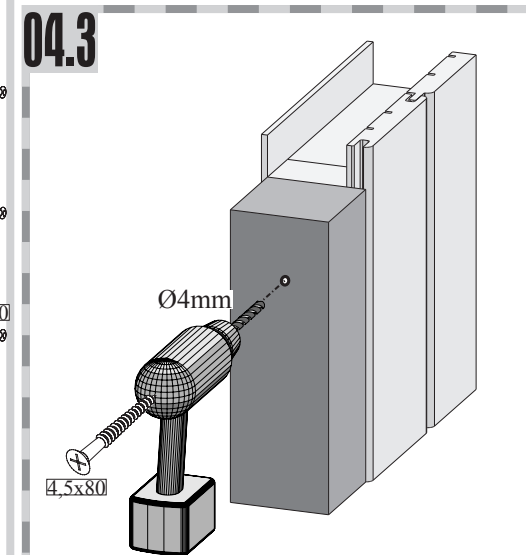
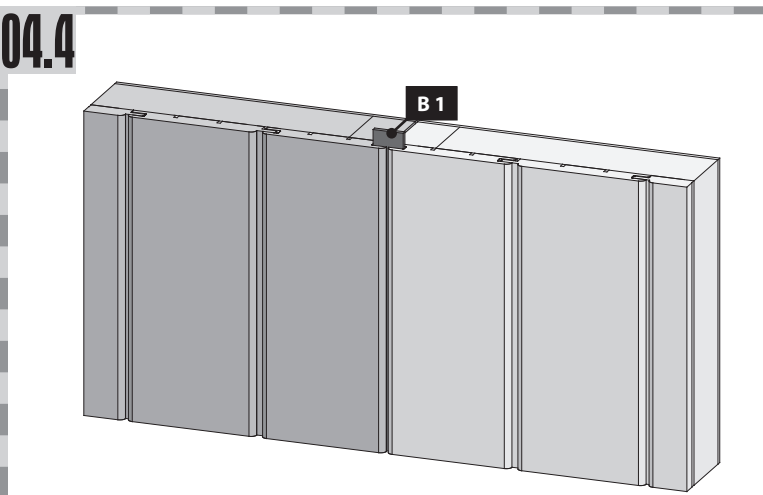
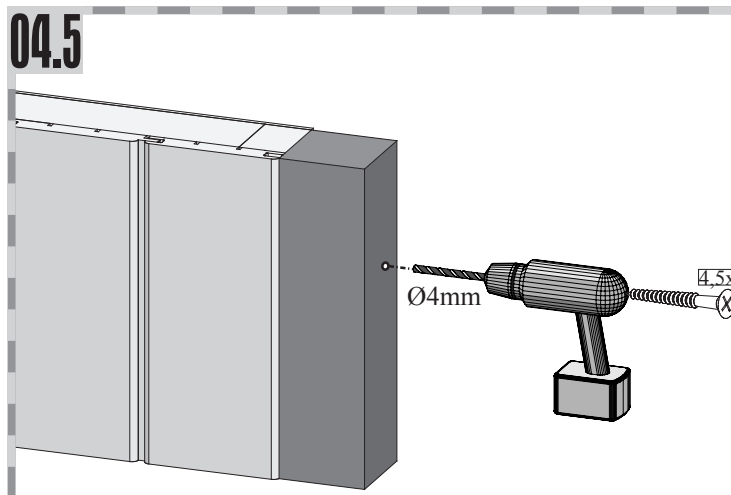
**03****04.1****04.2****04****04.3****04.4****04.5**

05

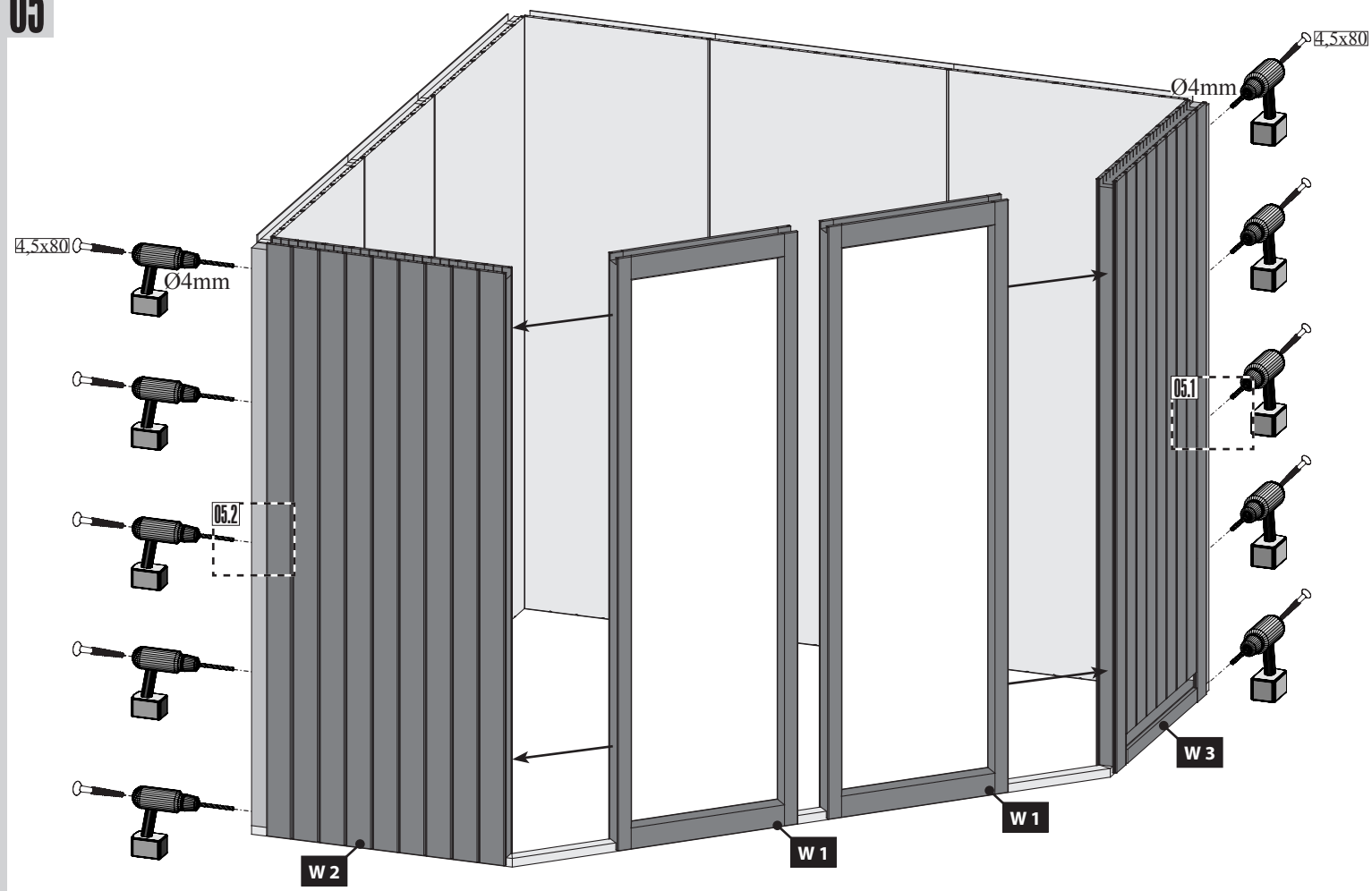

06

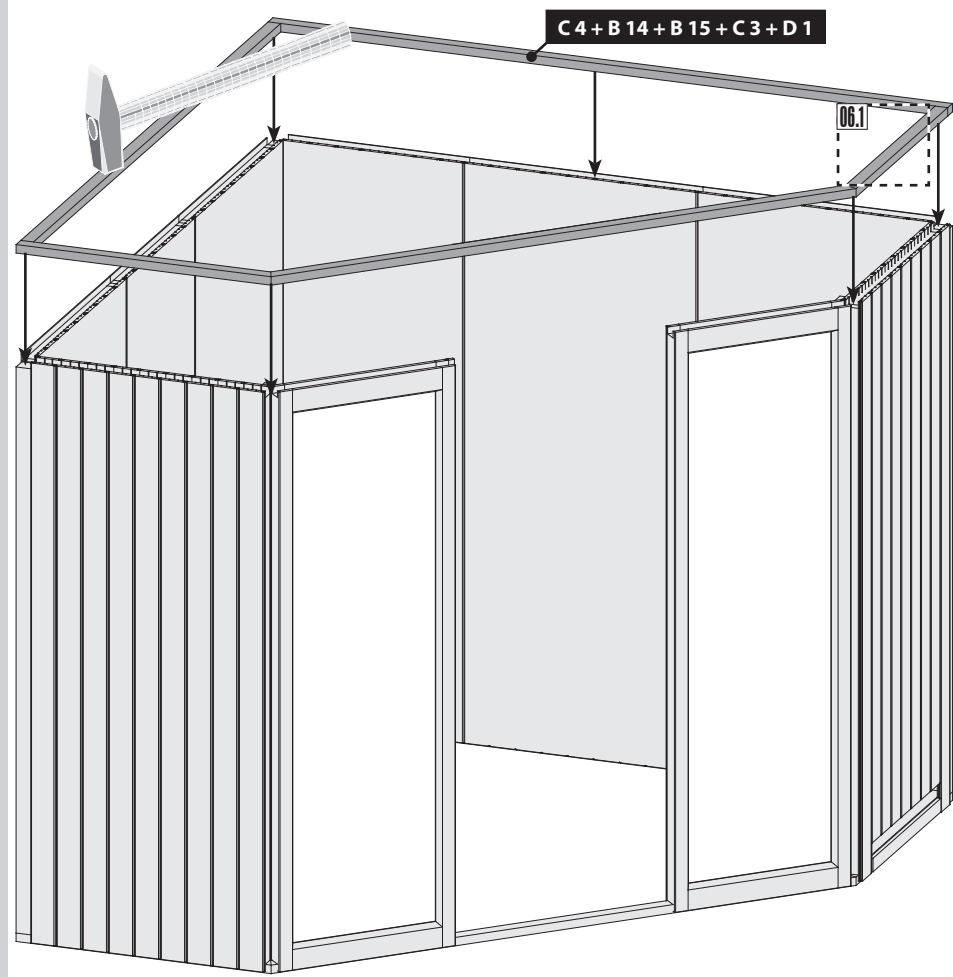

05.1

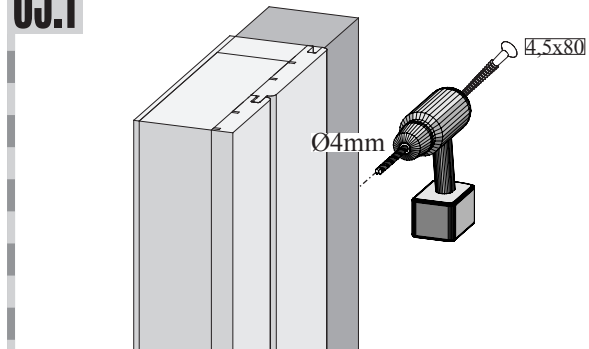

05.2

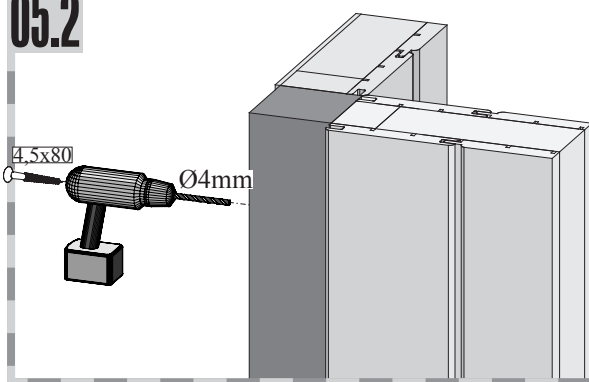

06.1

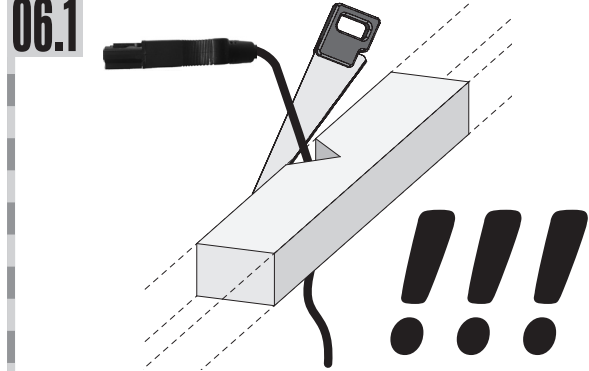



Einbau Glastür

Installation of glass door

Montaje de la puerta de cristal

Montage porte en verre

Montage van de glazen deur

Installazione portello di vetro

**!!! 01 — 03 !!!**

**07**

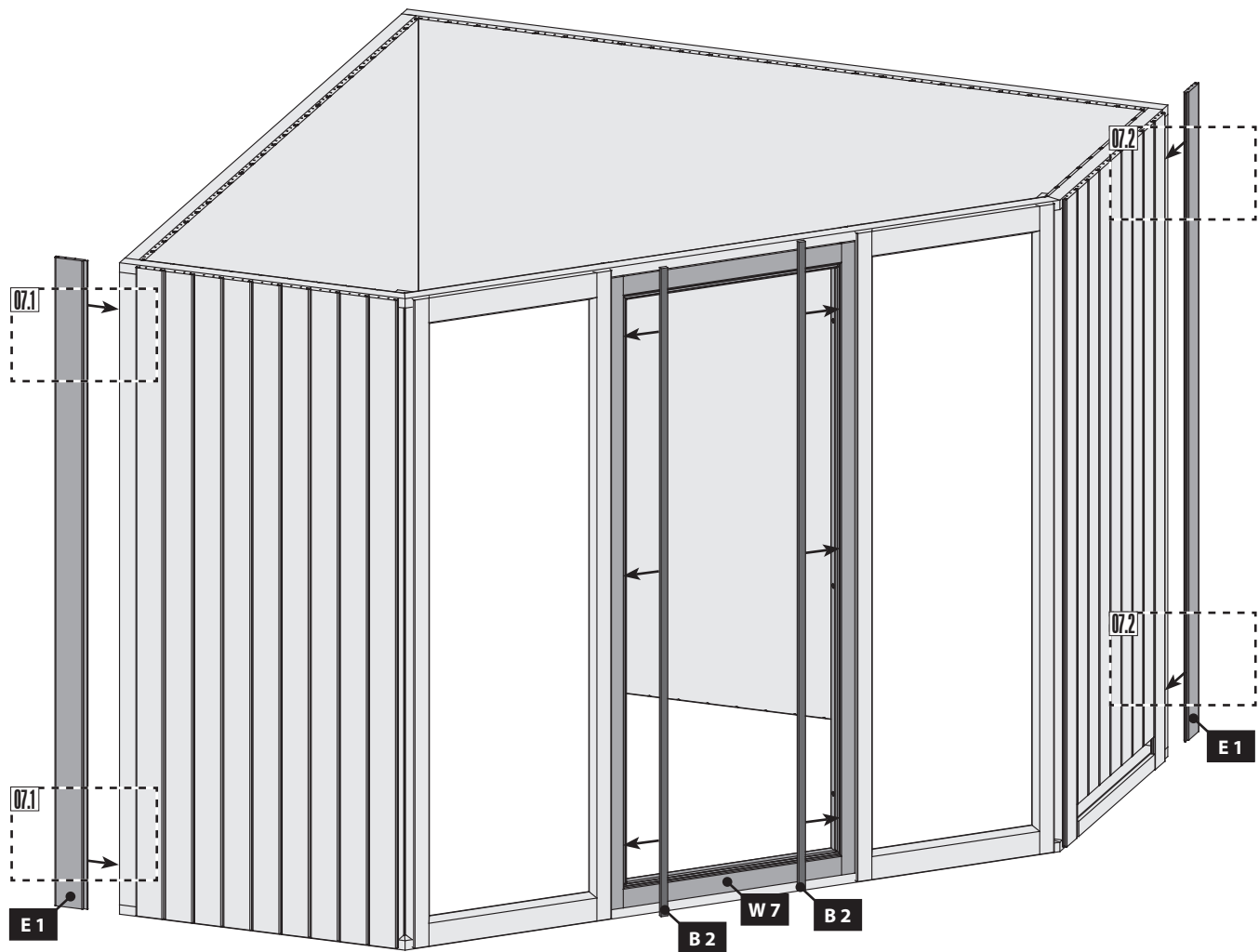

**08**

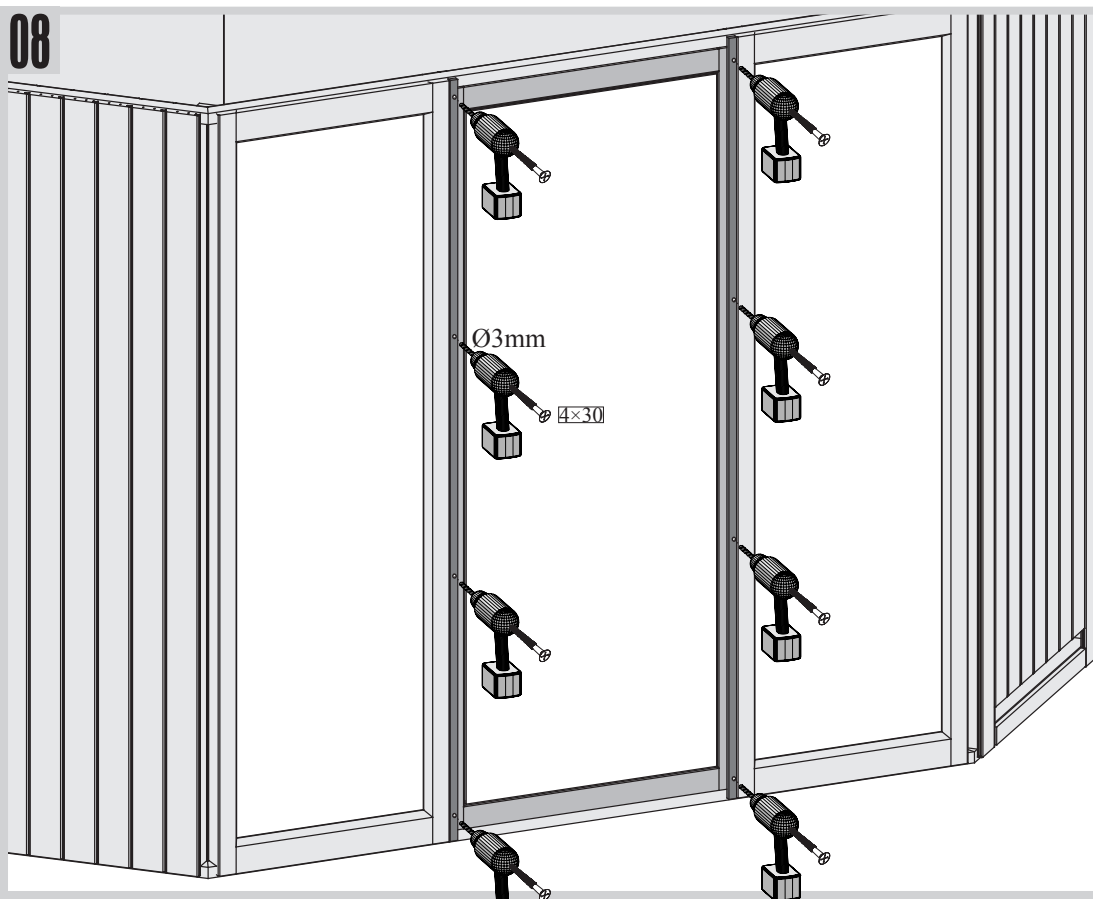

**07.1**

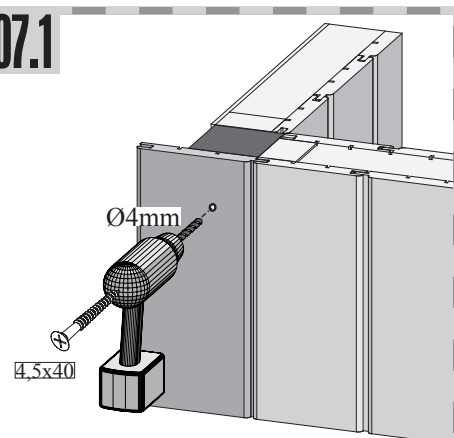

**07.2**

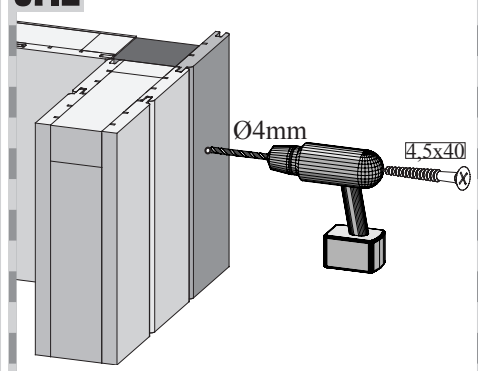

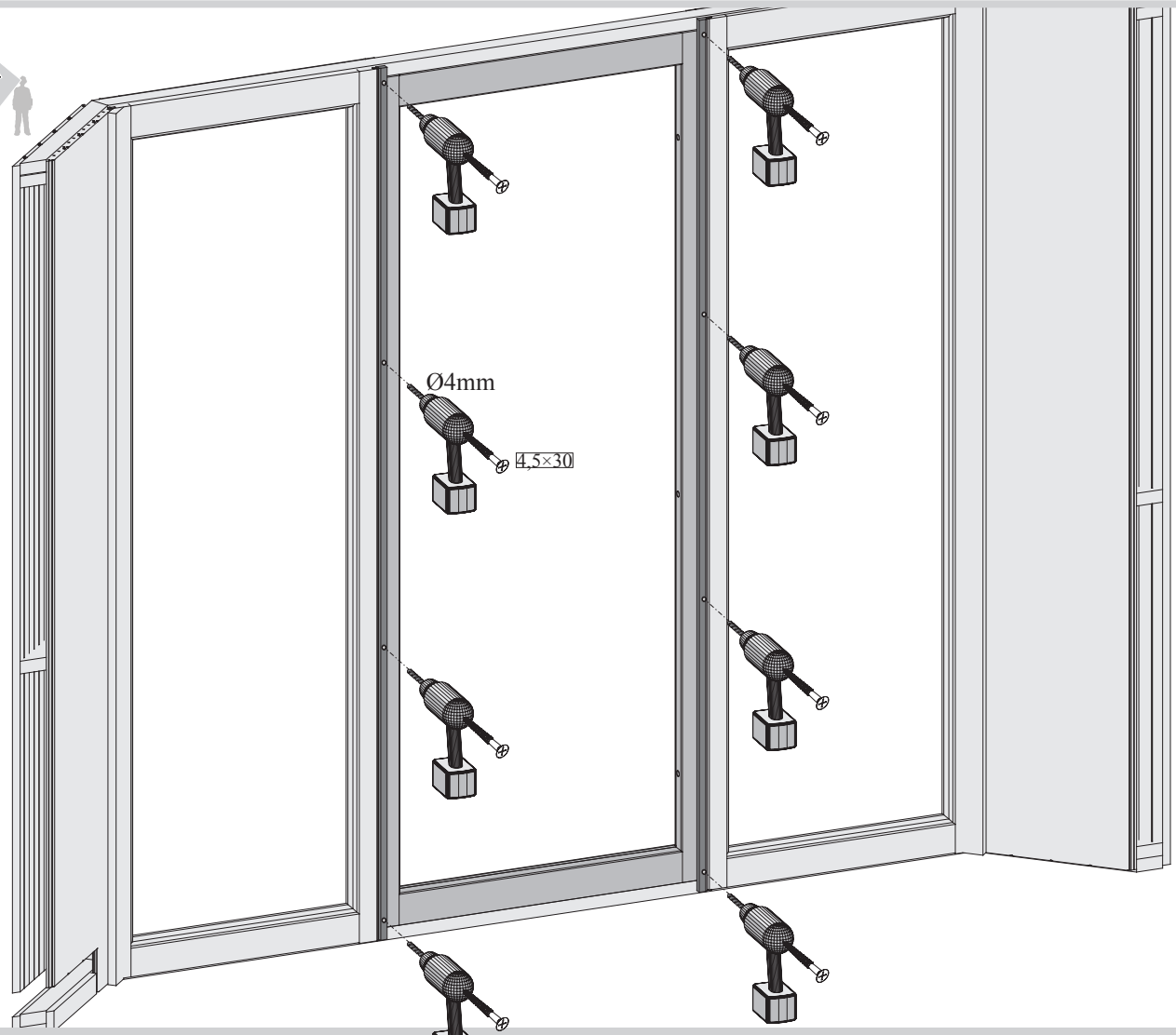
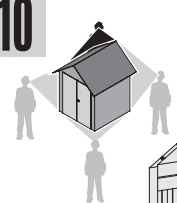
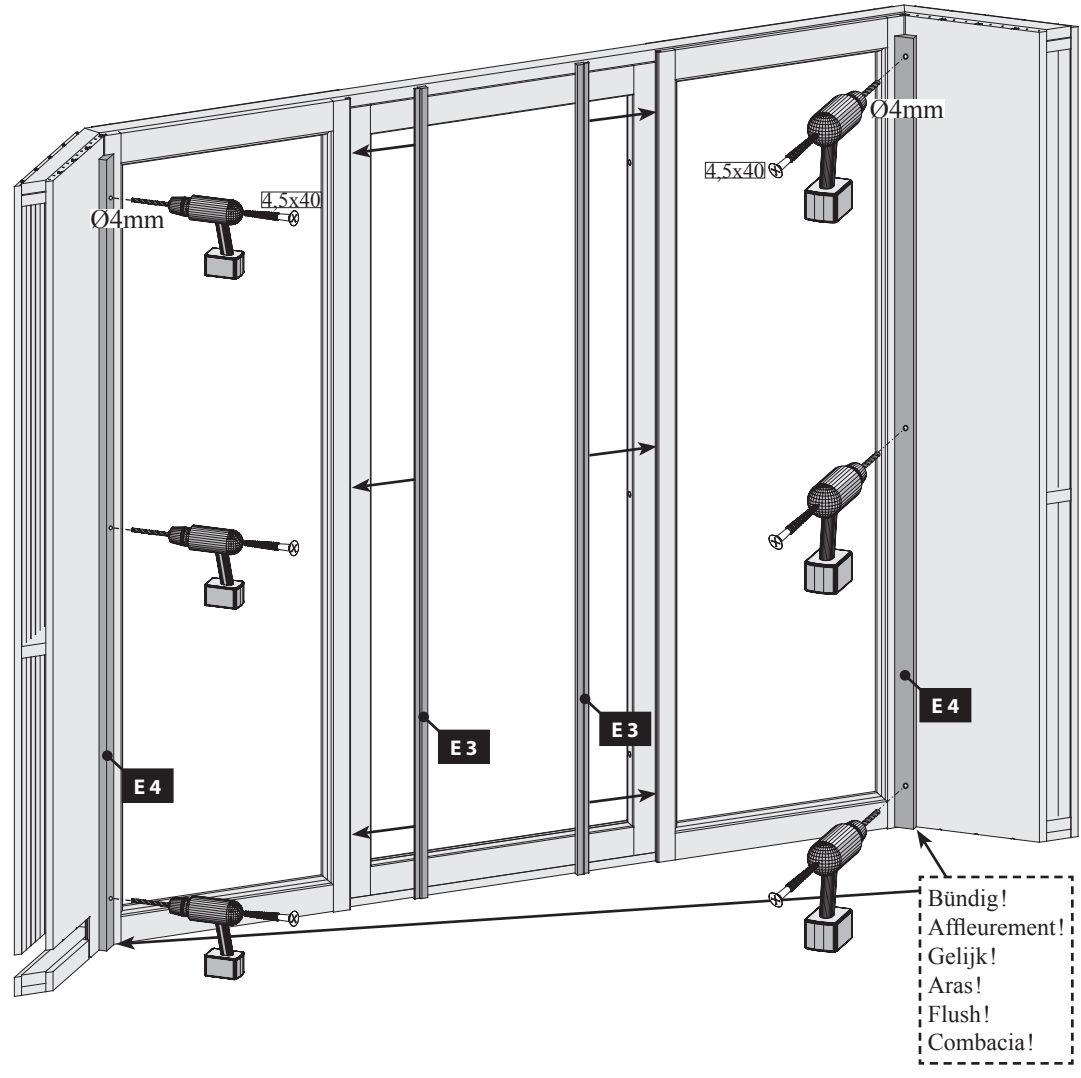
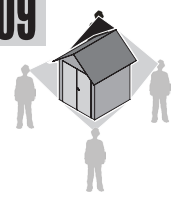

12

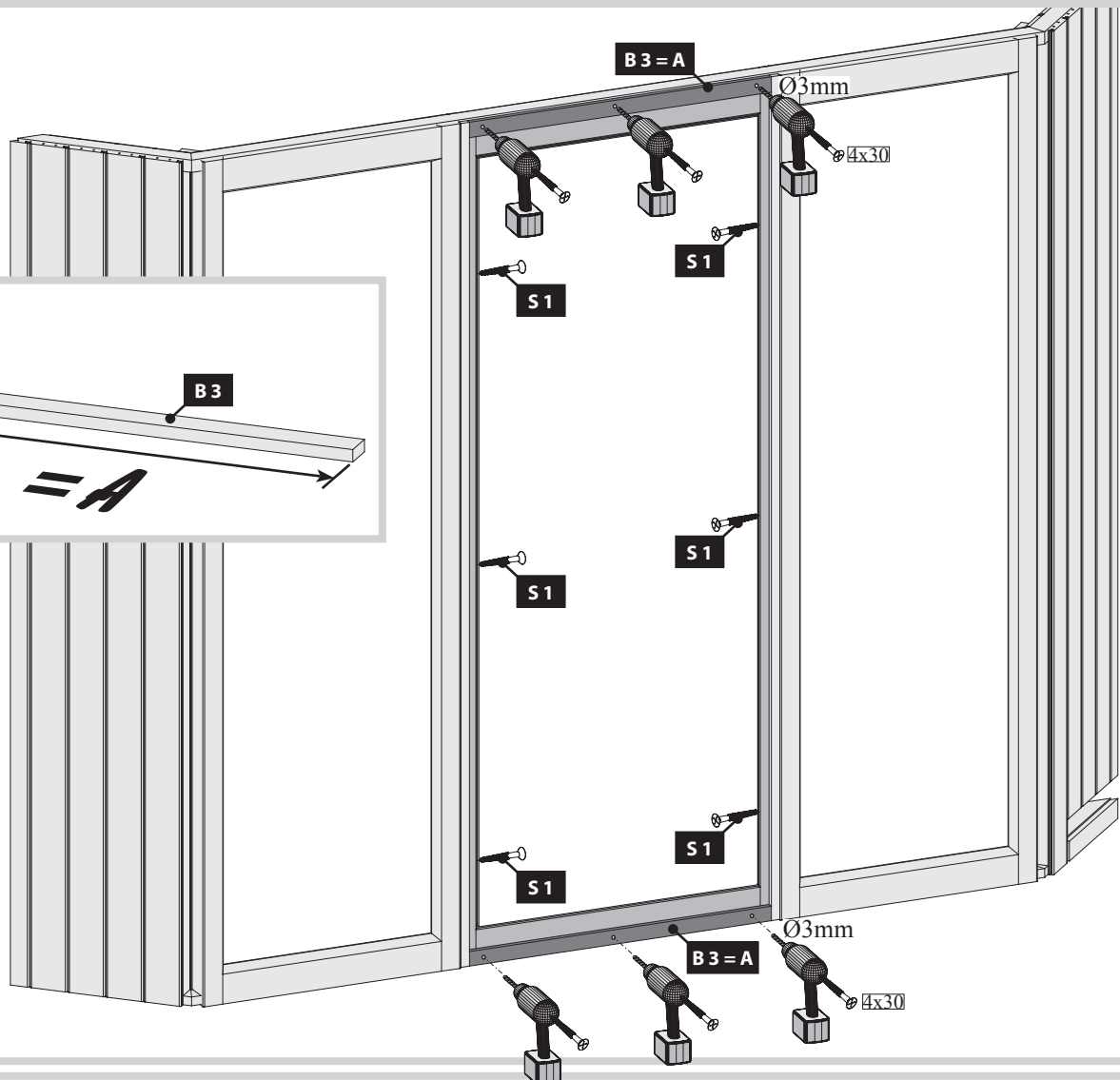
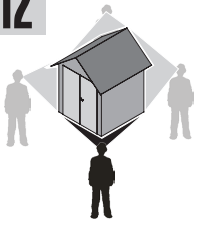

13

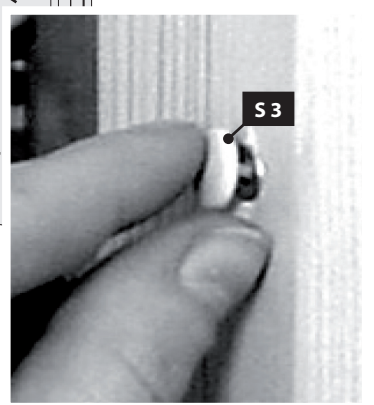
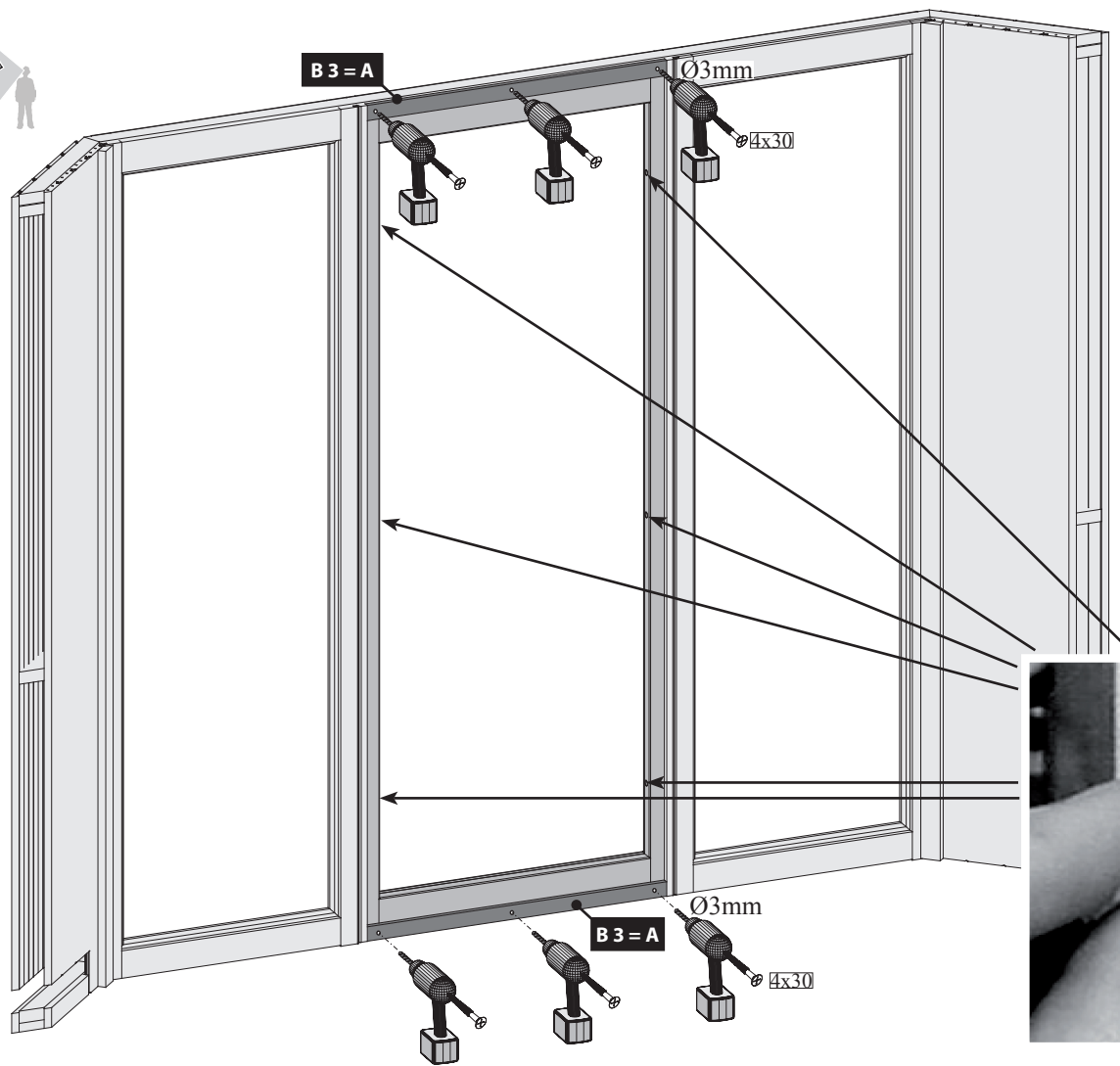
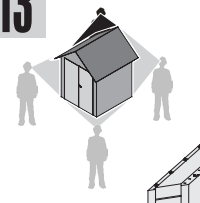

14

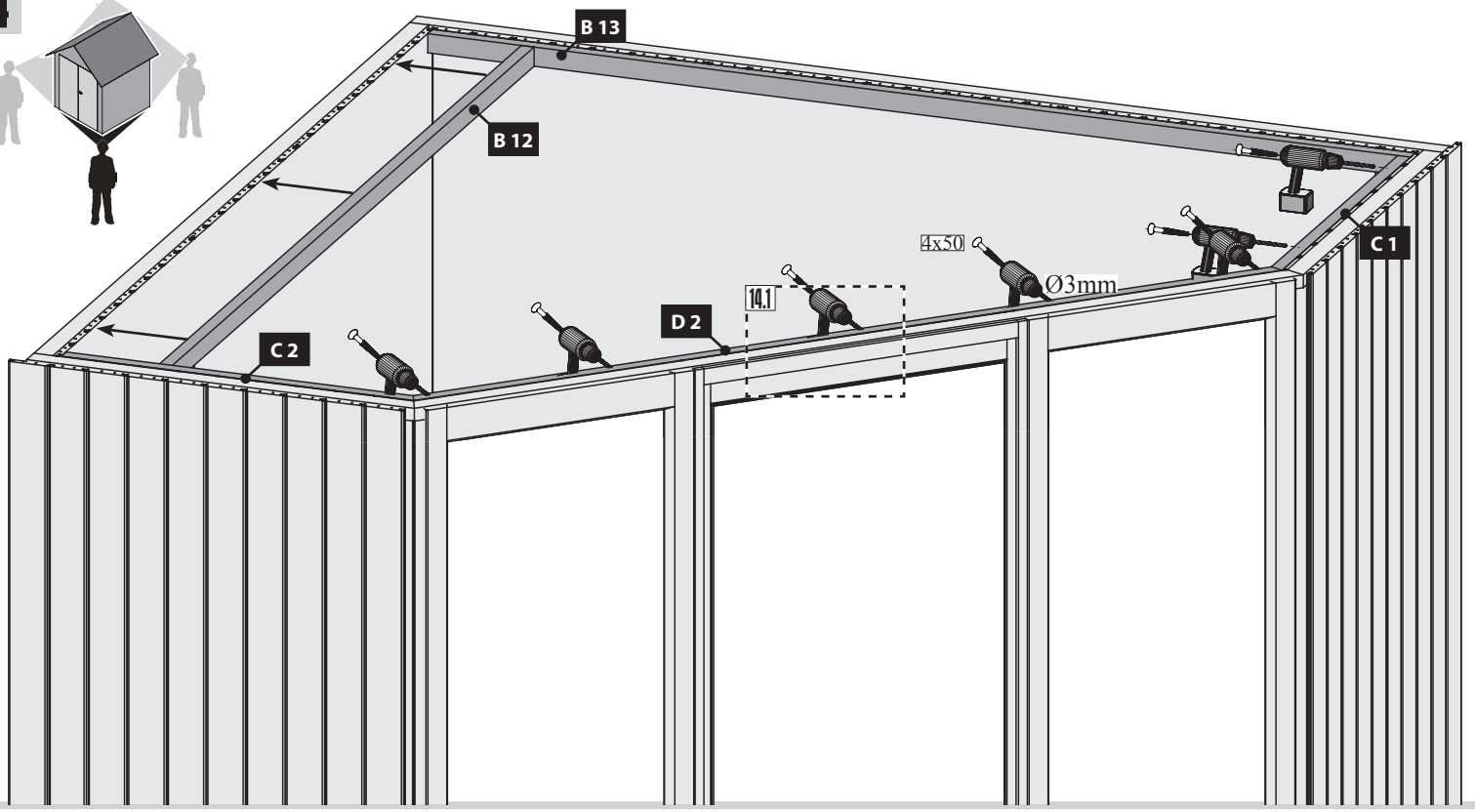
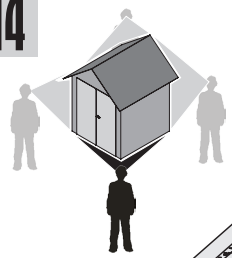

15

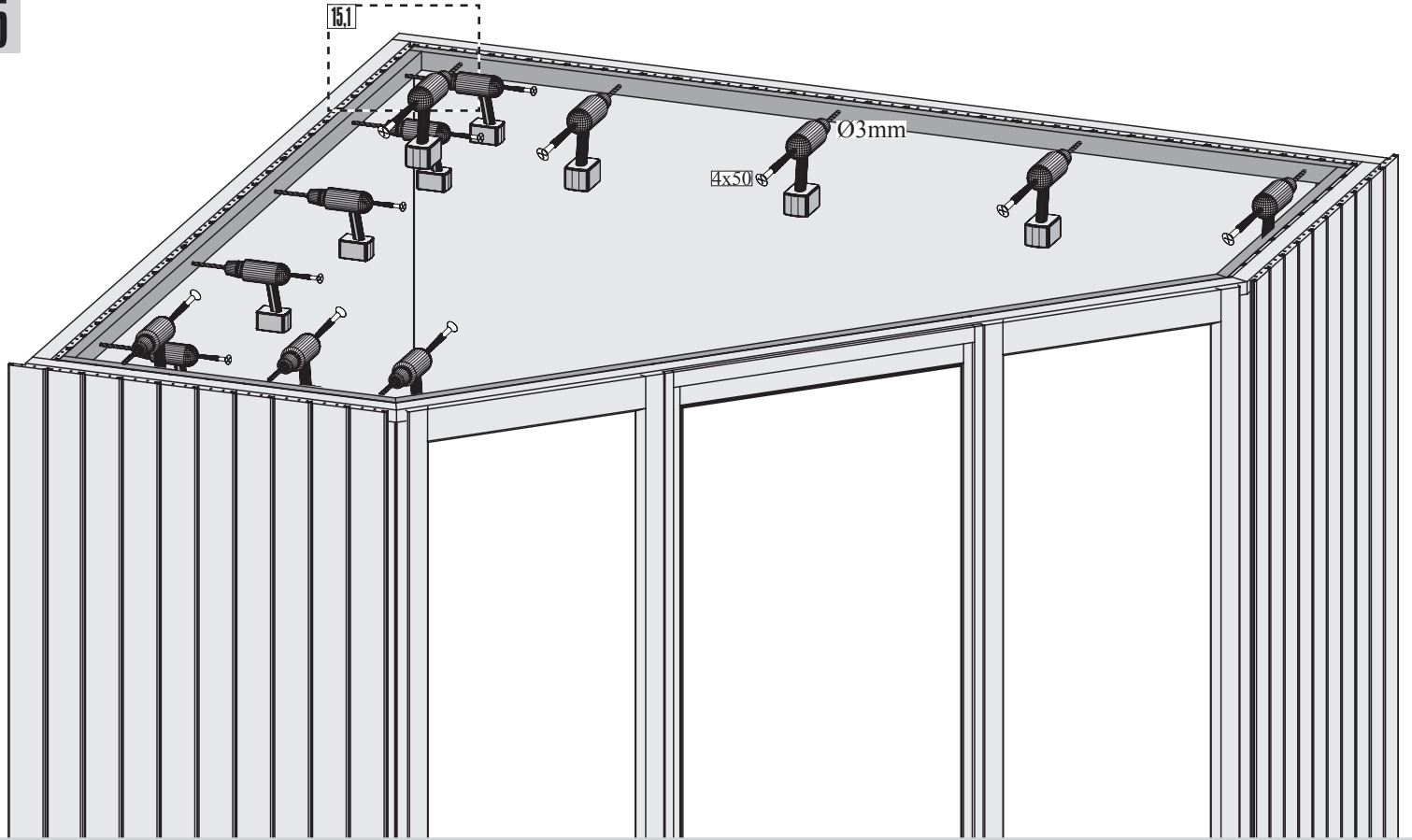

14.1

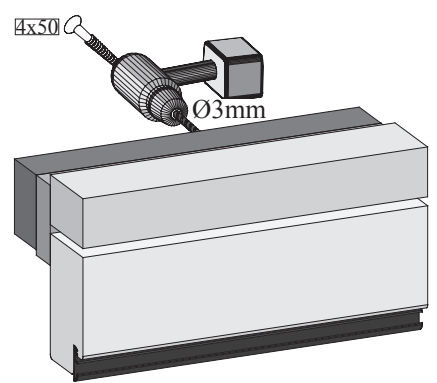

15.1

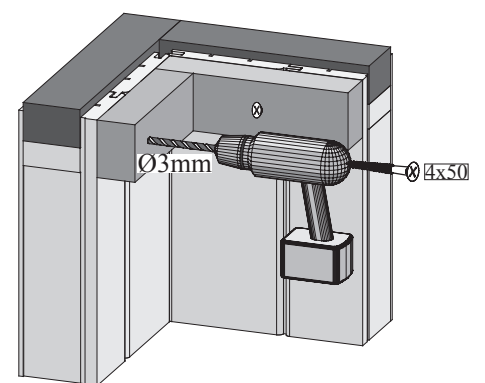

16

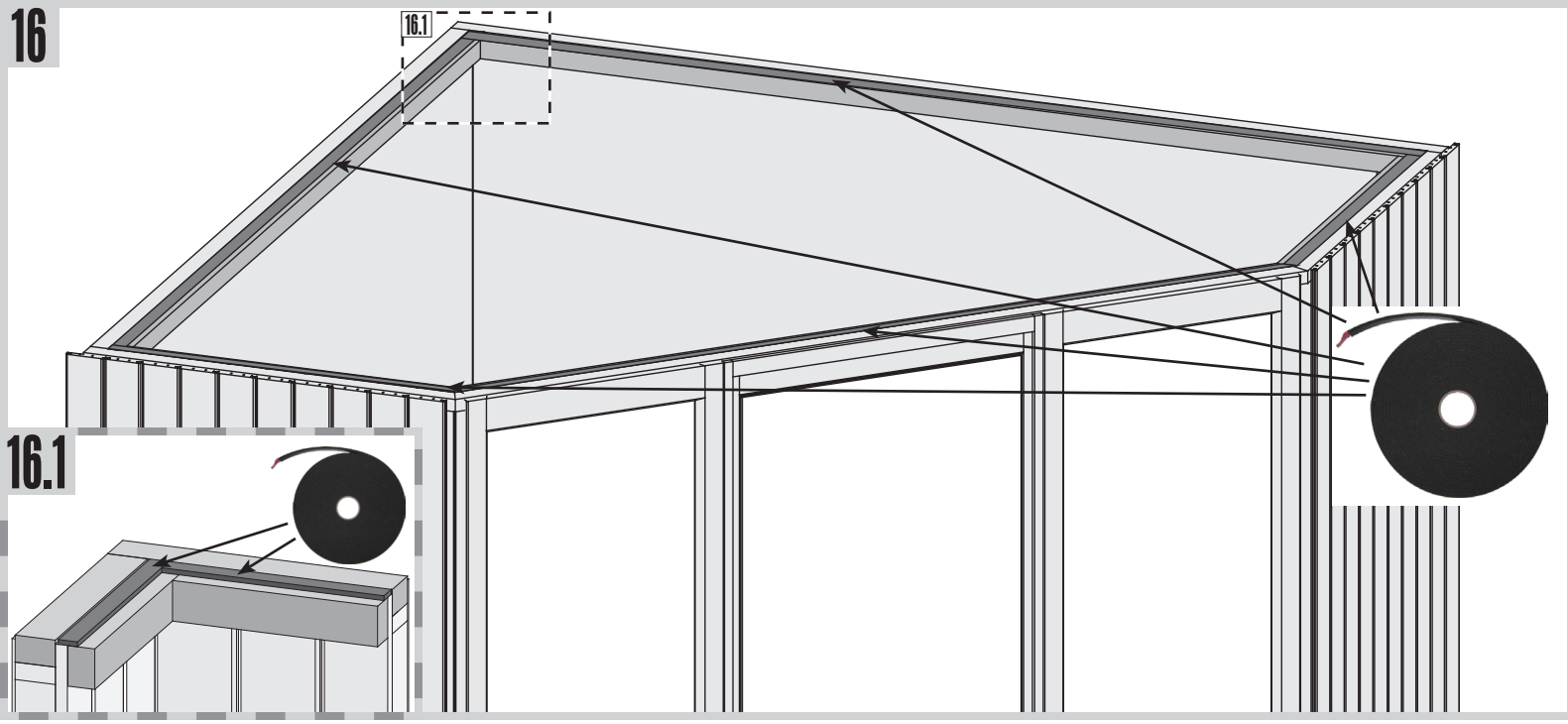

16.1

17

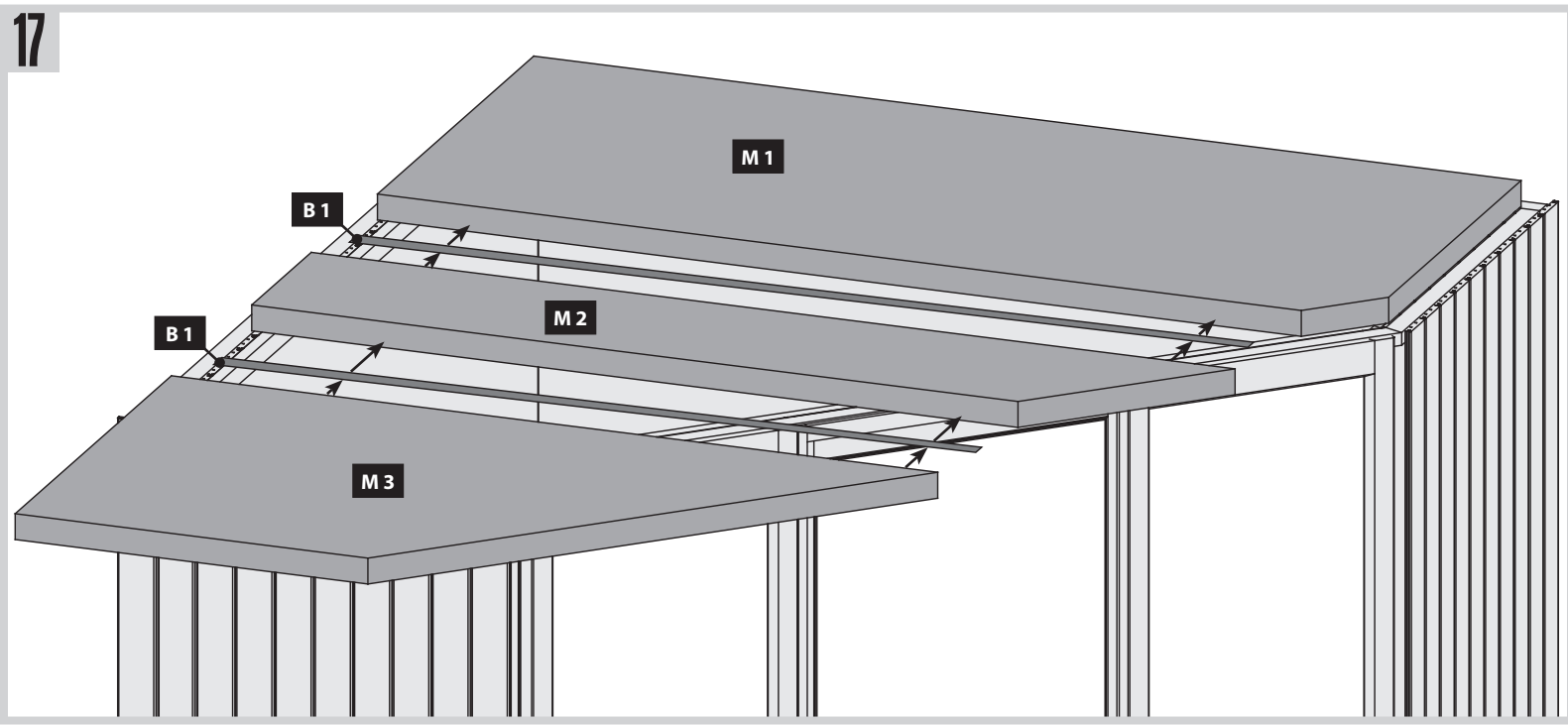

18

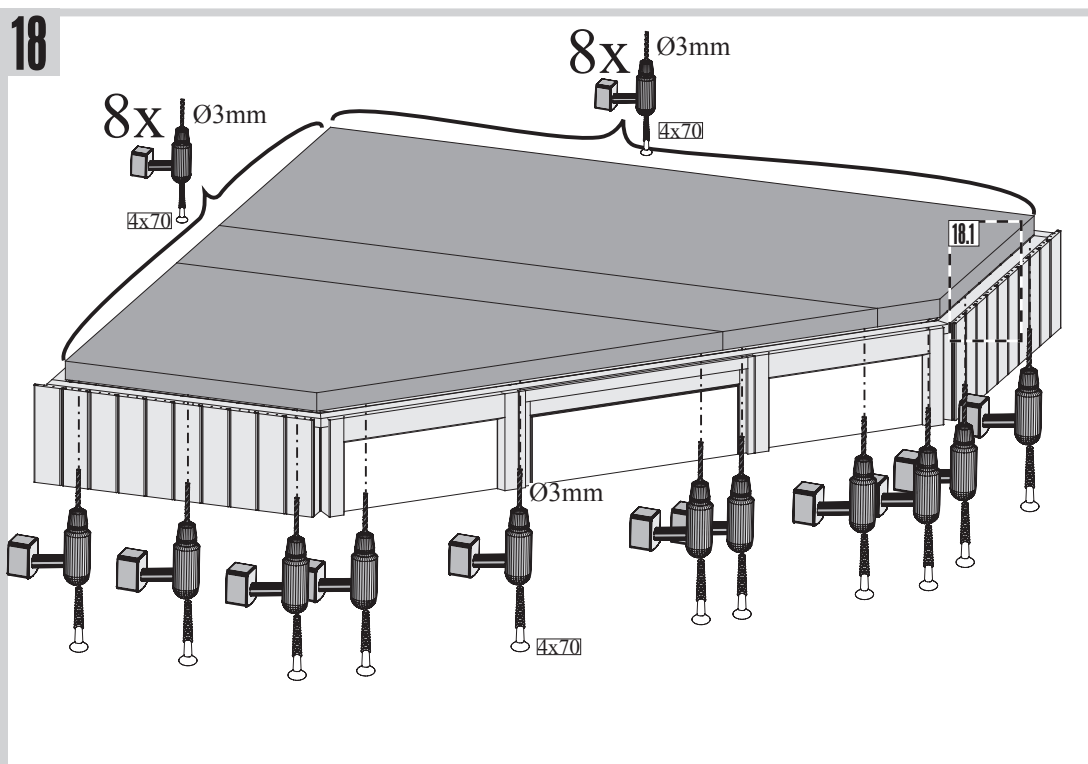

18.1

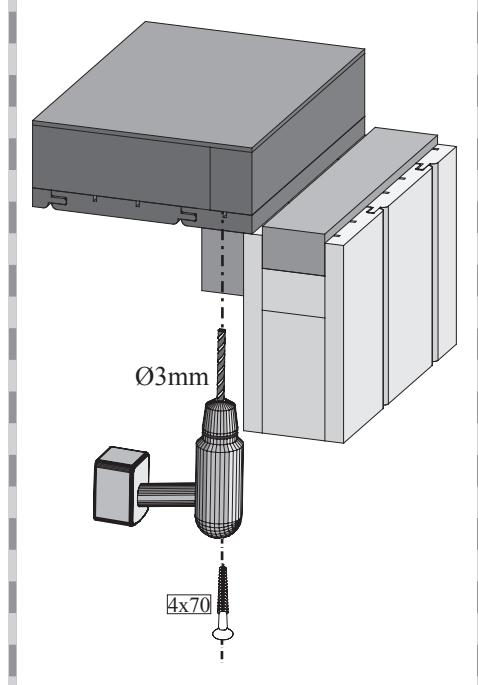



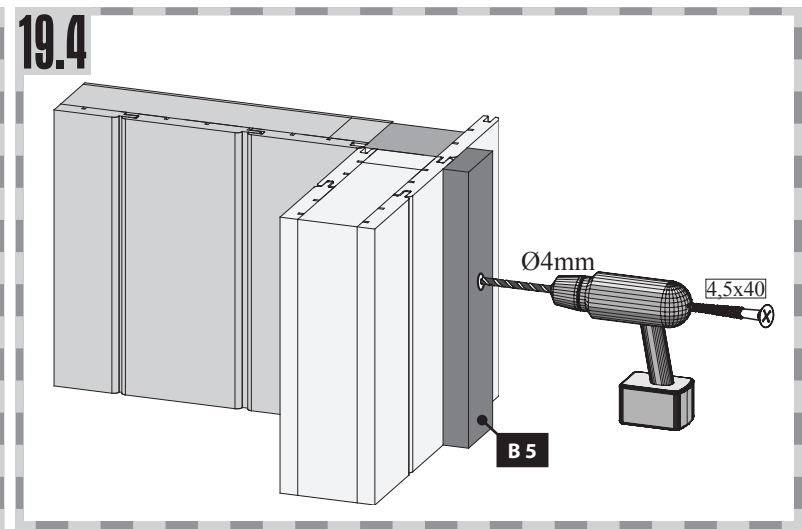
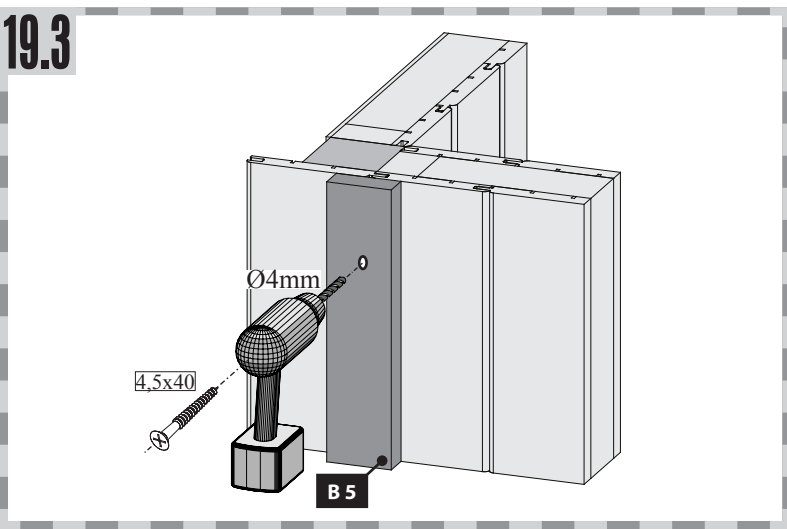
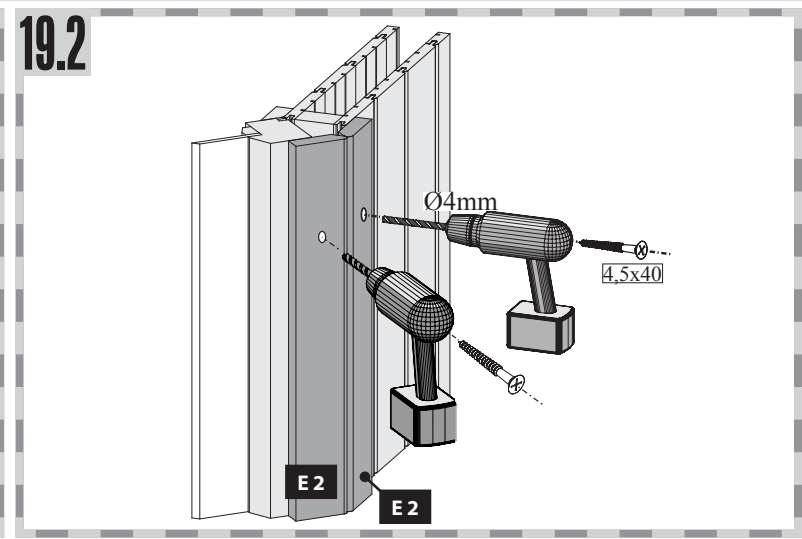
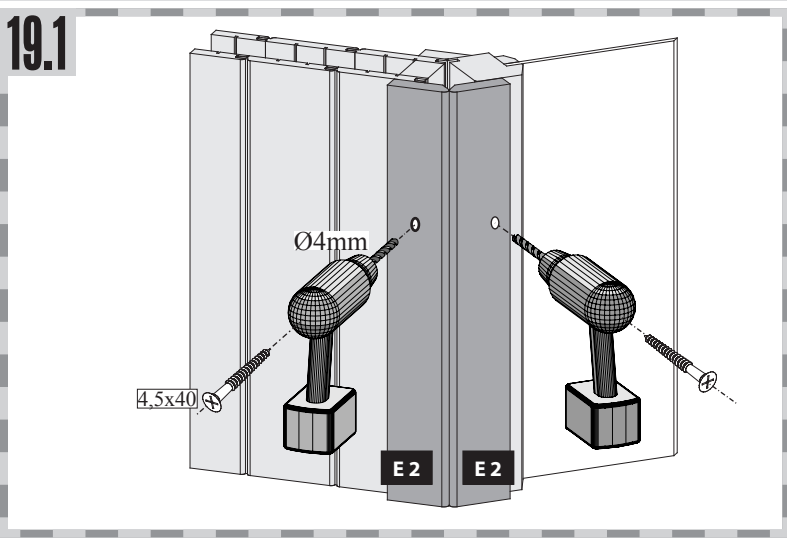
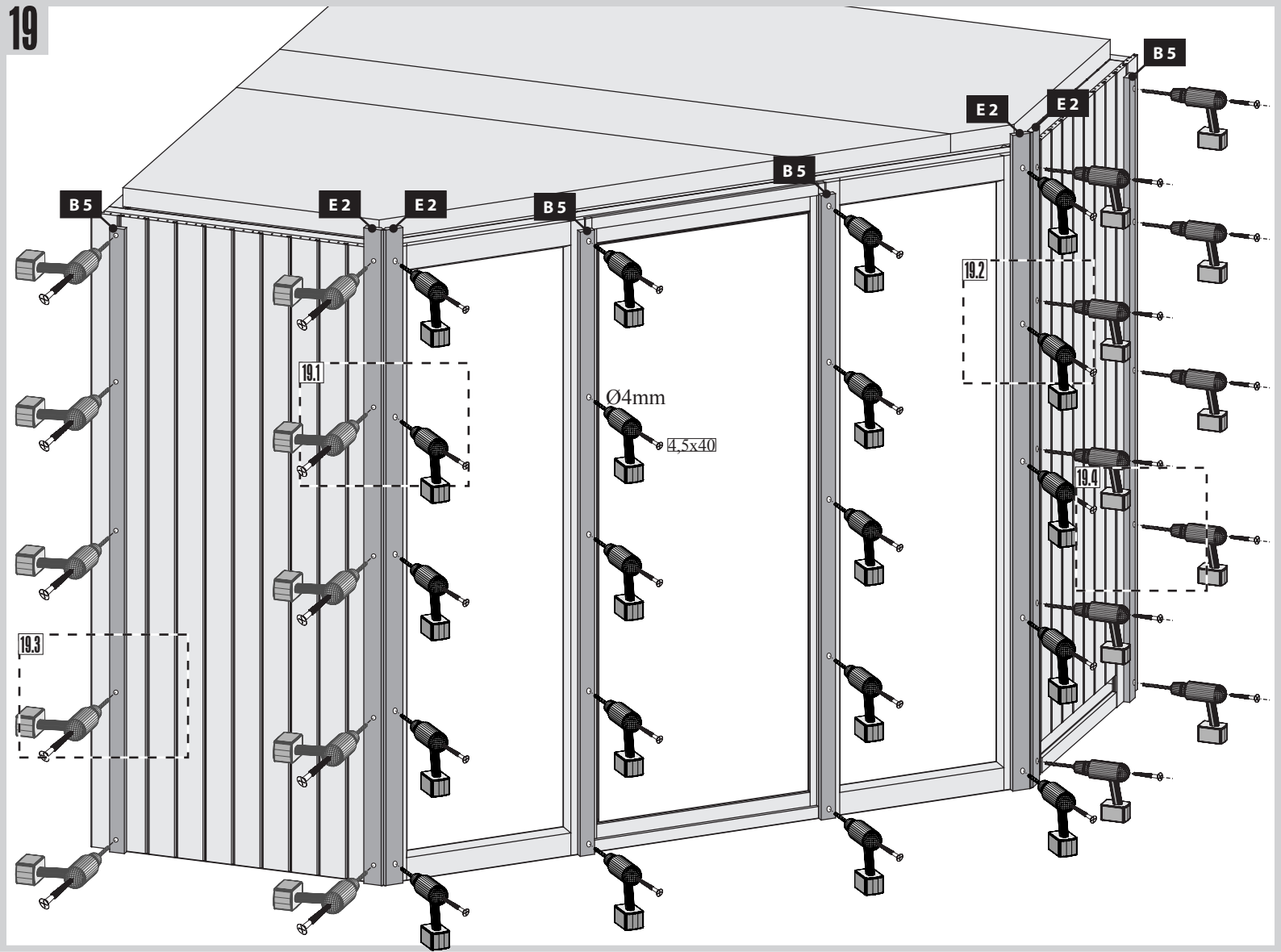

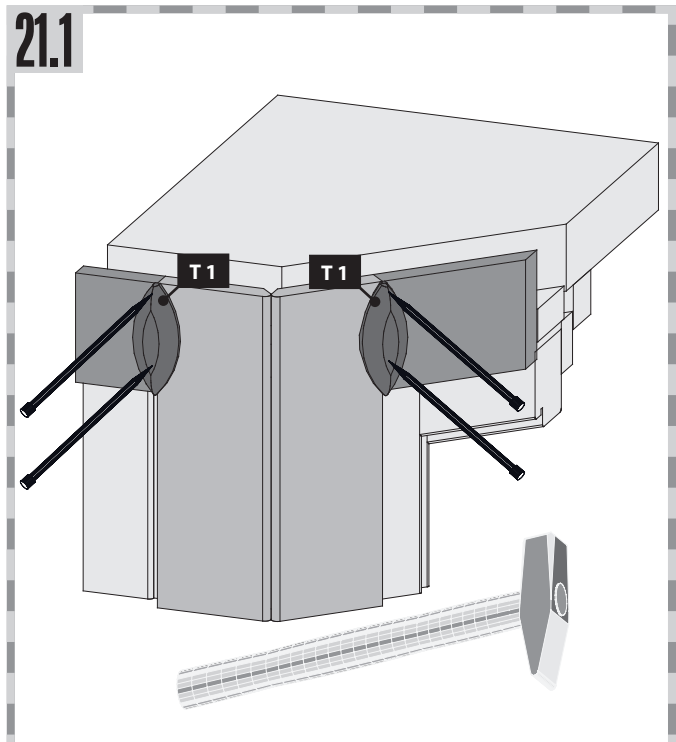
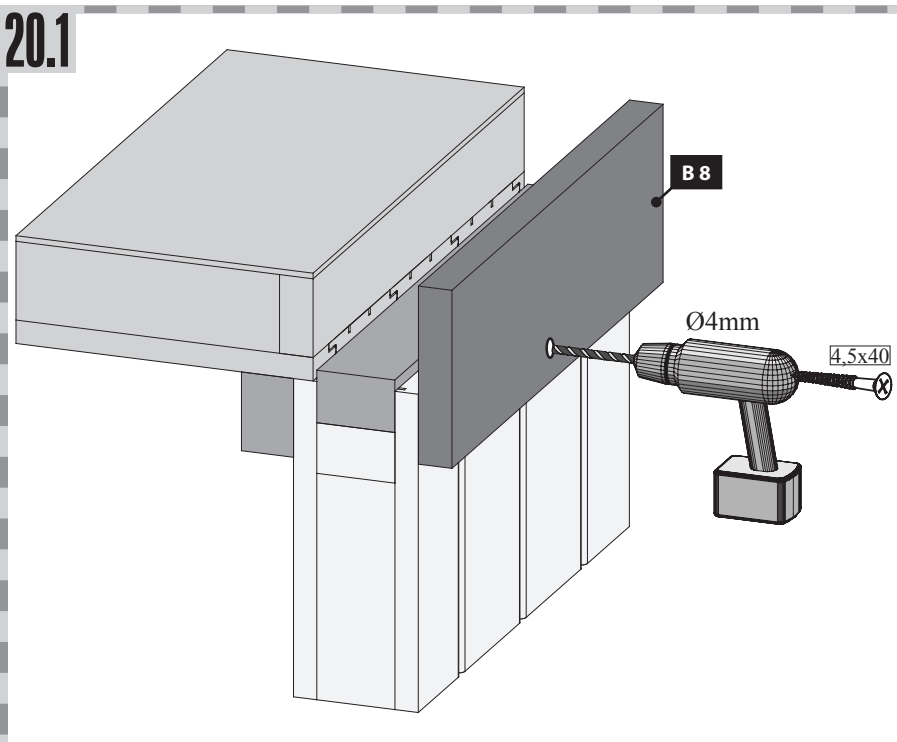
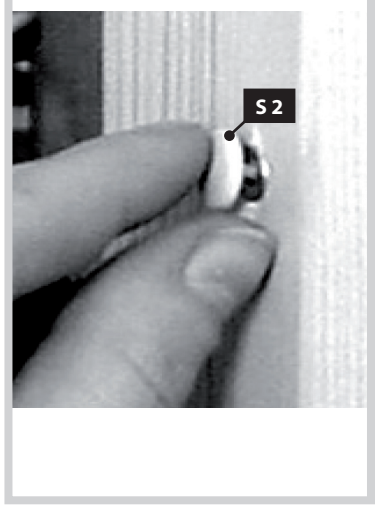
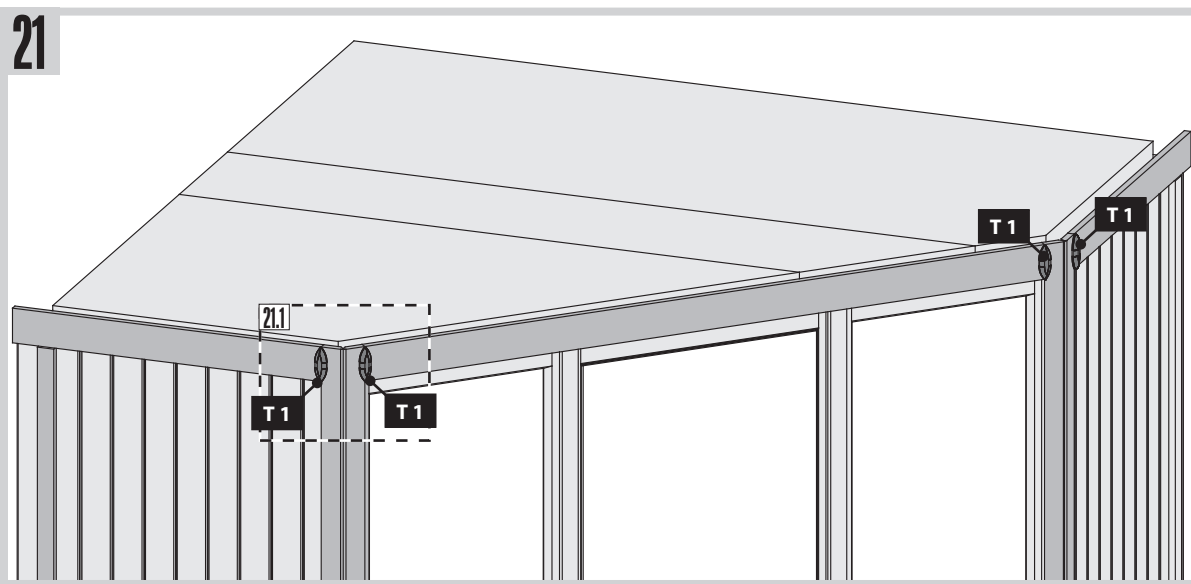
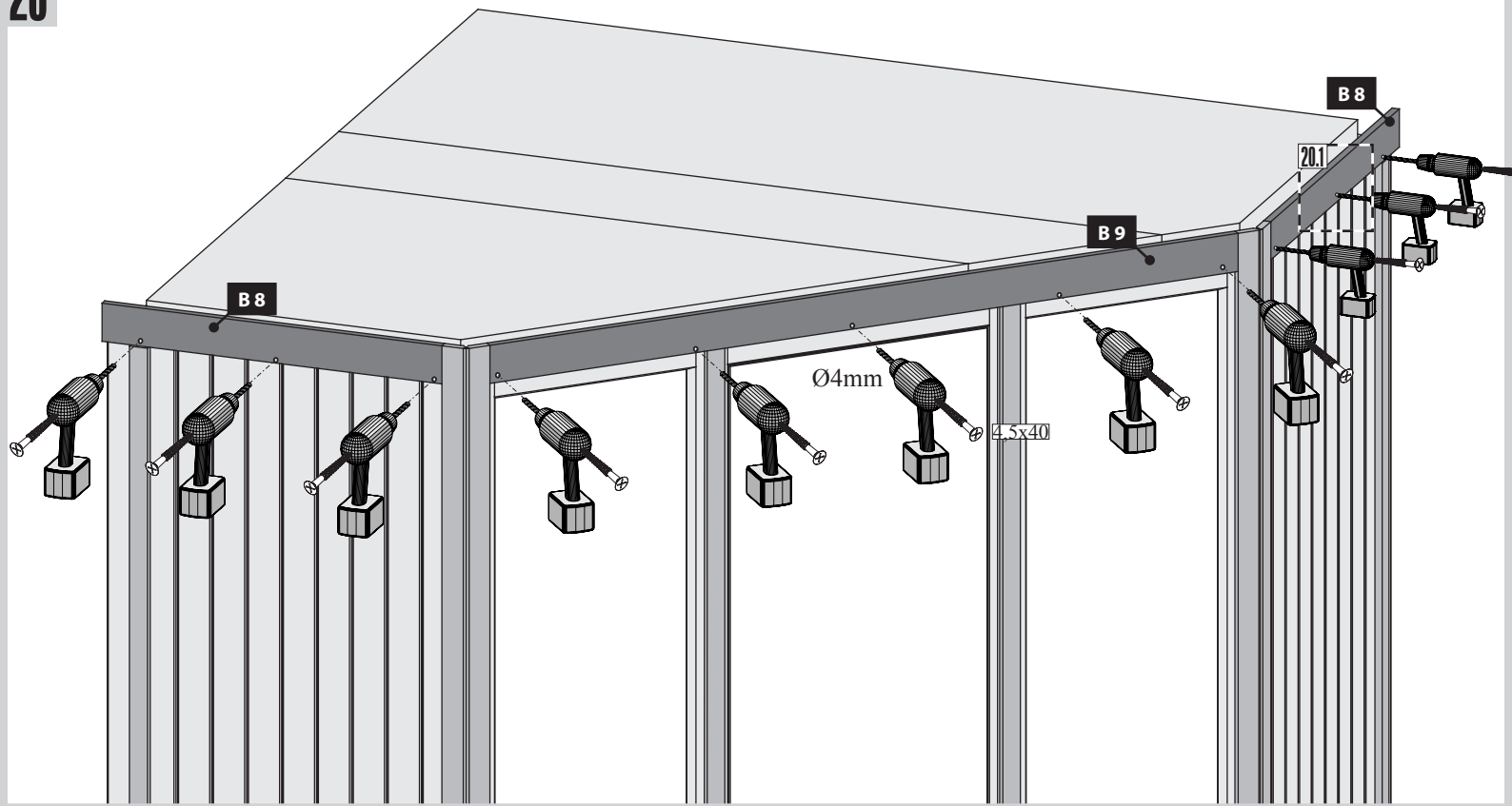

23

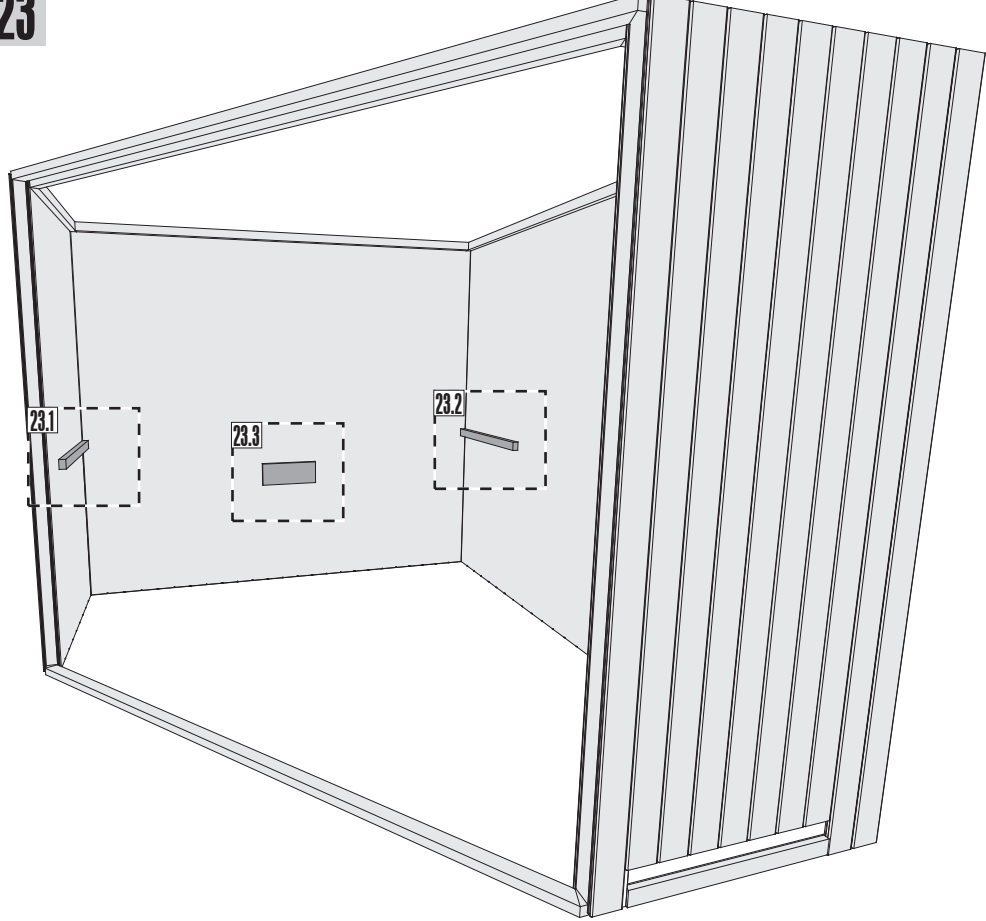

23.1

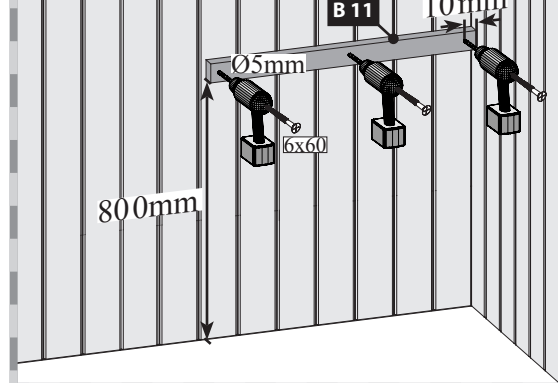

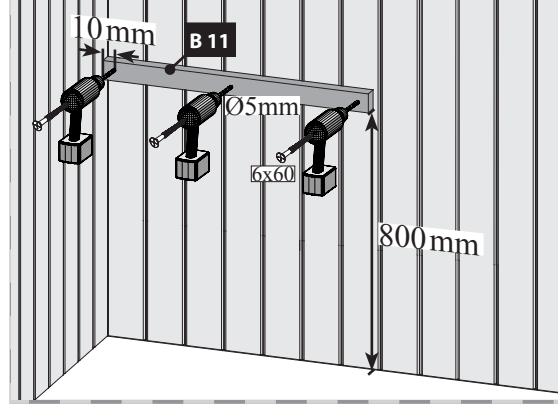

23.2



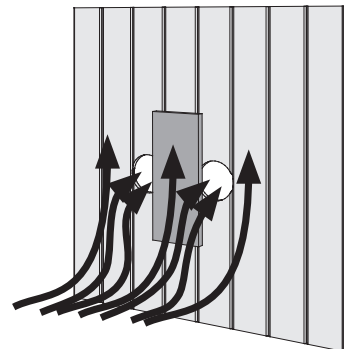
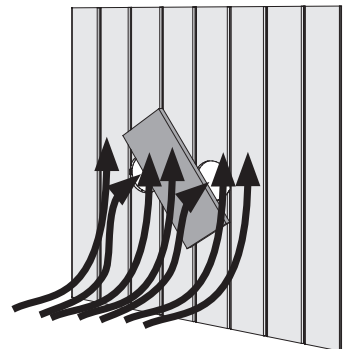
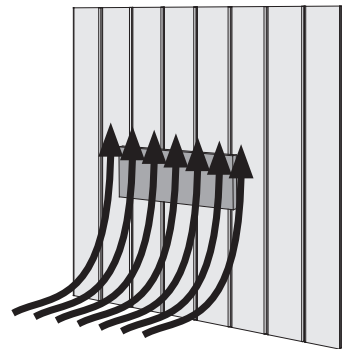
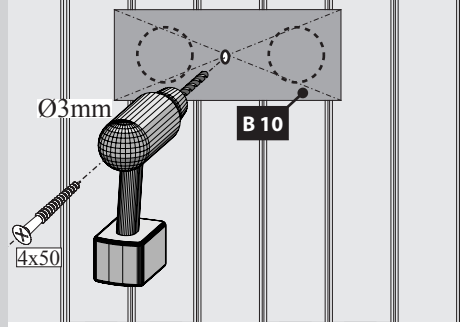

23.3



 Hier ist die Funktionsweise des Brettes abgebildet. Regeln Sie damit die Abluft nach Ihren eigenen Wünschen.

 Ceci représente le mode de fonctionnement de la planche. Avec elle, réglez l'écoulement de l'air selon vos désirs.

 This figure shows the functional principle of the board. Regulate the exhaust air according to your own wishes.

 Hier is de werking van het plankje afgebeeld. Regel daarmee de luchtafvoer naar eigen wens.

 Aquí está representada la forma de funcionamiento de la tabla. Regule con ello el aire de salida según sus propios deseos.

 Viene illustrato il principio di funzionamento della tavoletta di regolazione della ventilazione. Con essa si può regolare a piacere la ventilazione.

24 2x

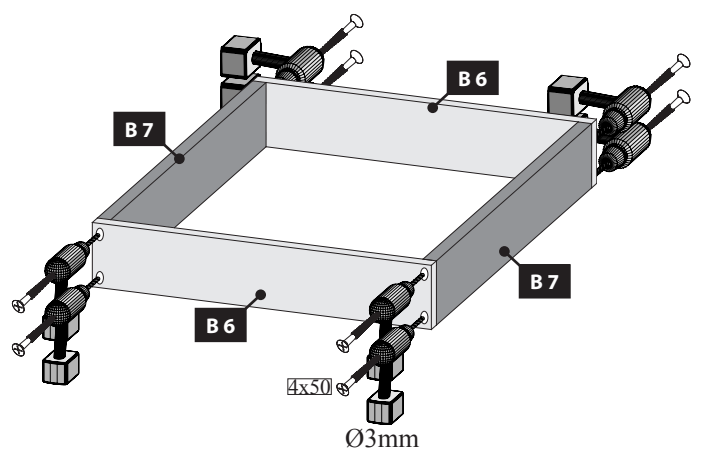

25

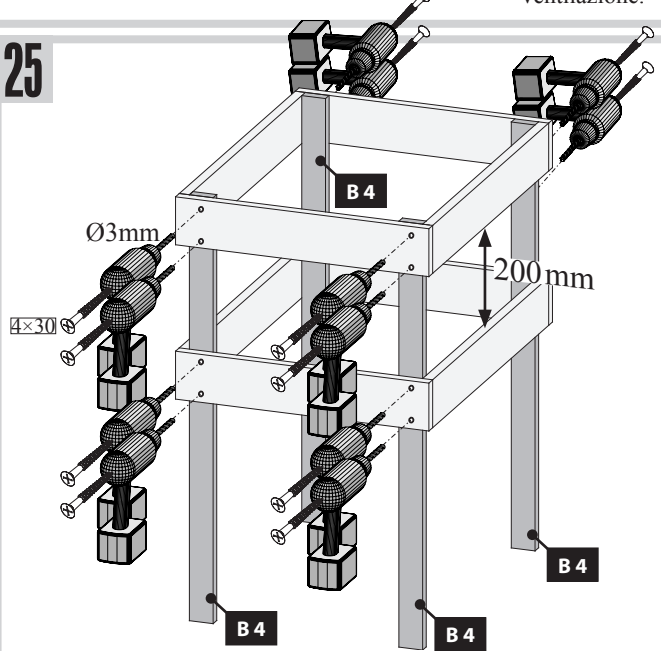

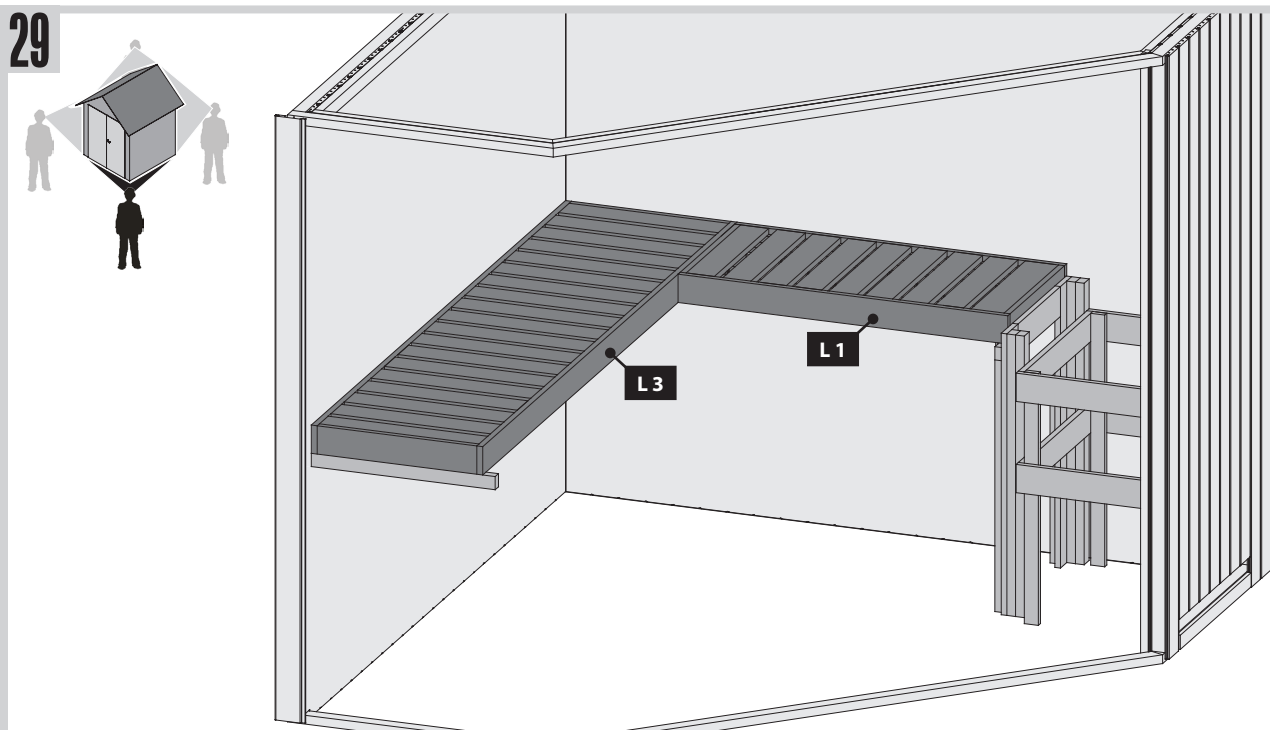
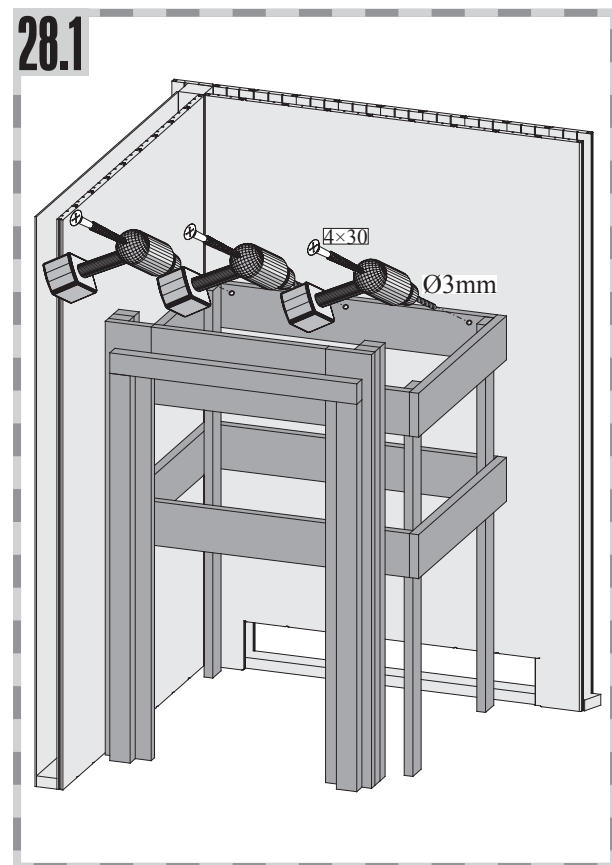
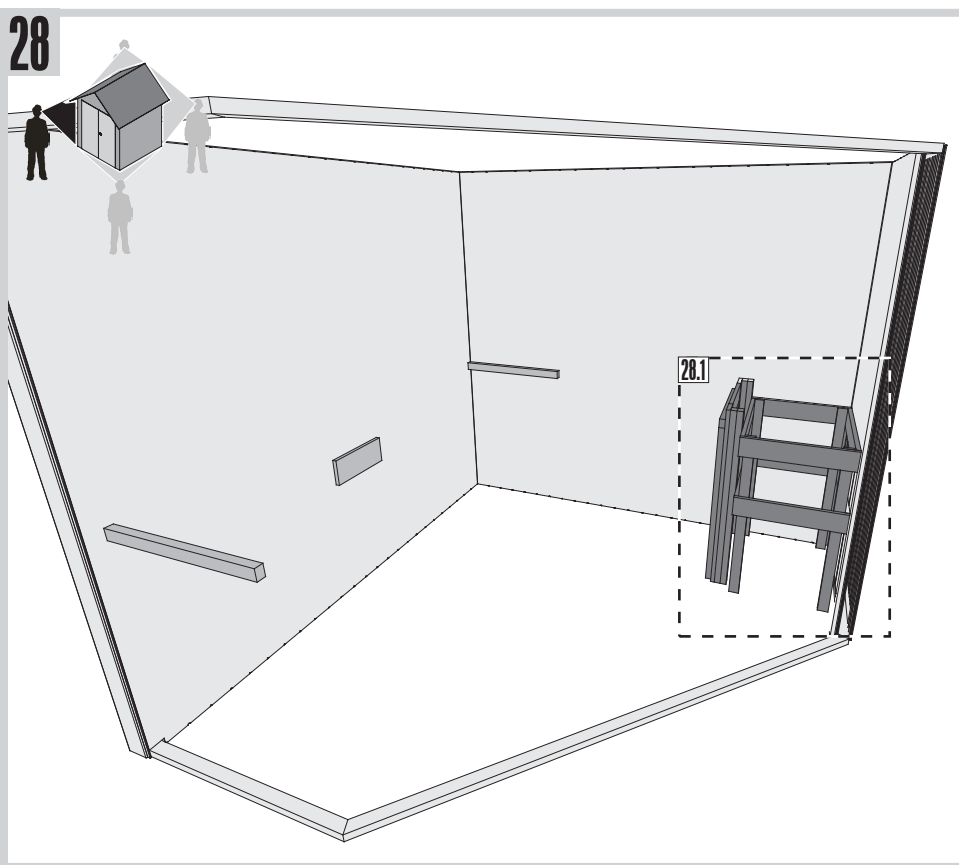
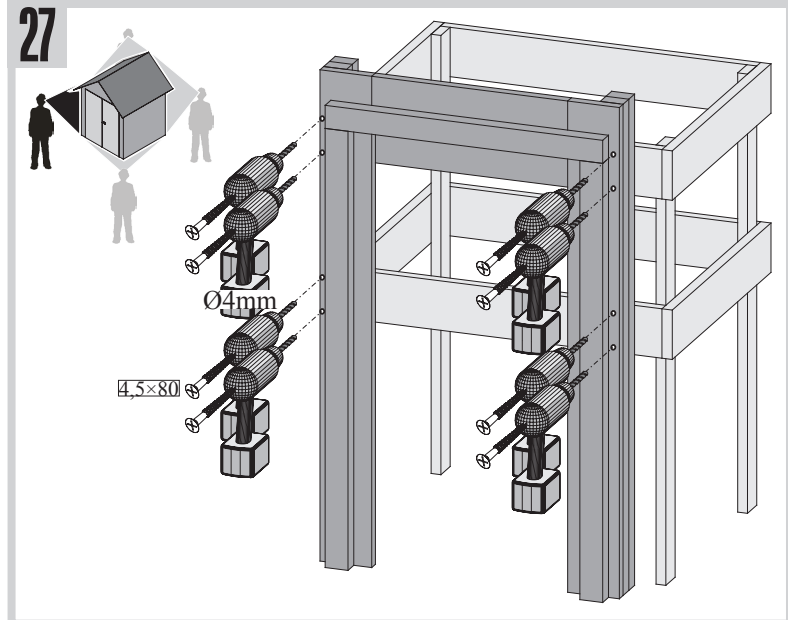
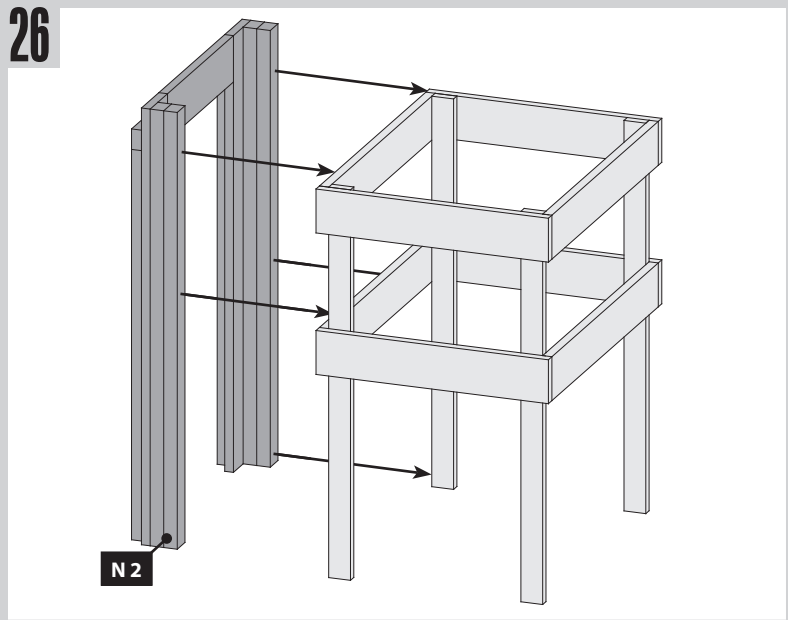

30

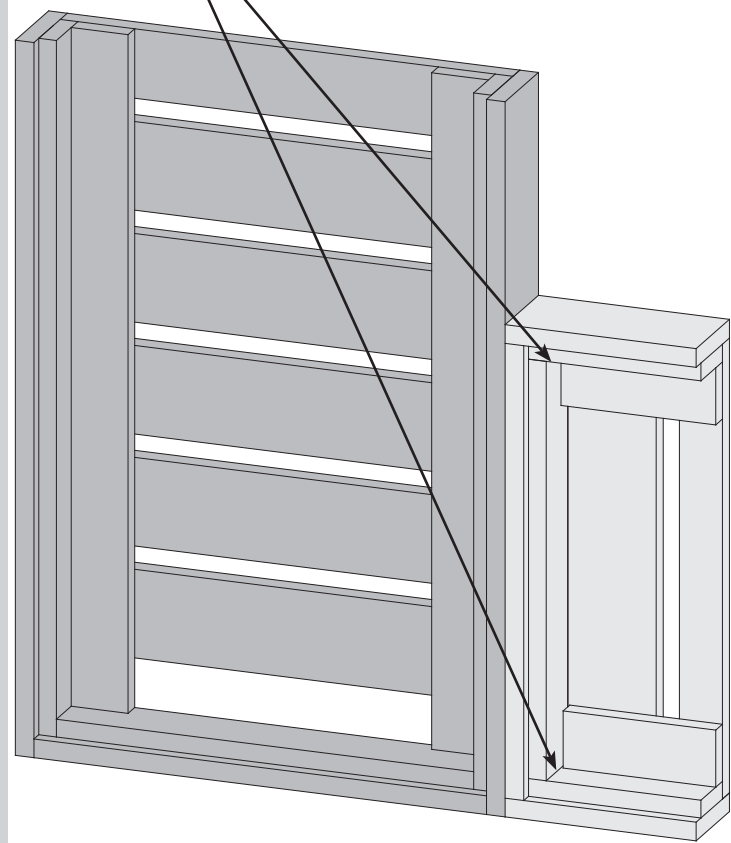
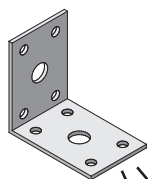
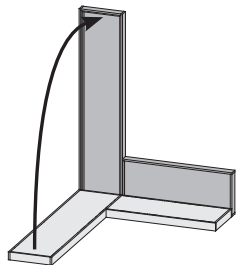

31

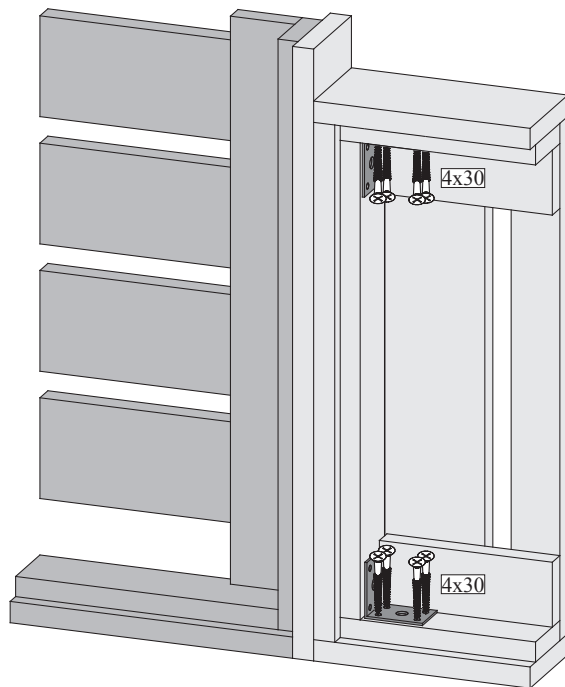

32

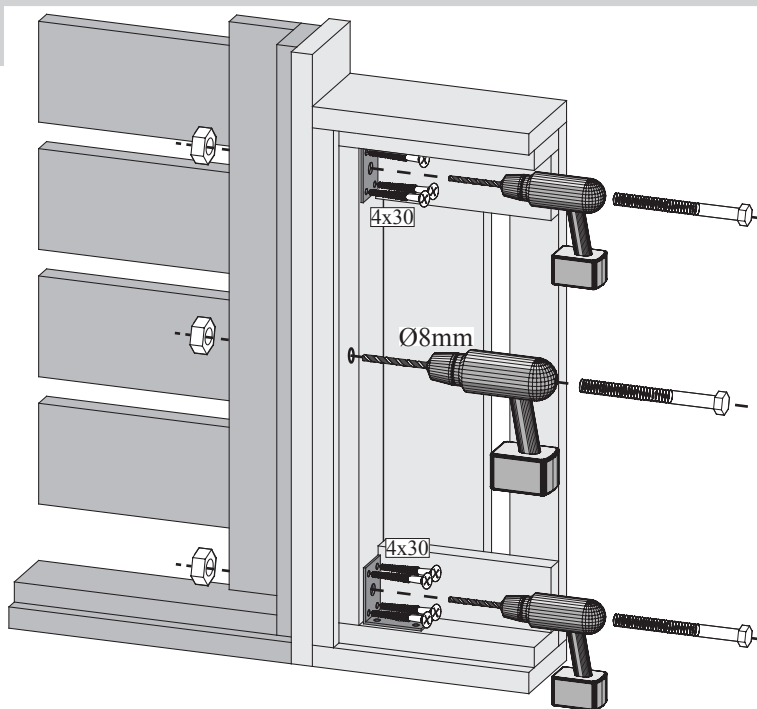

33

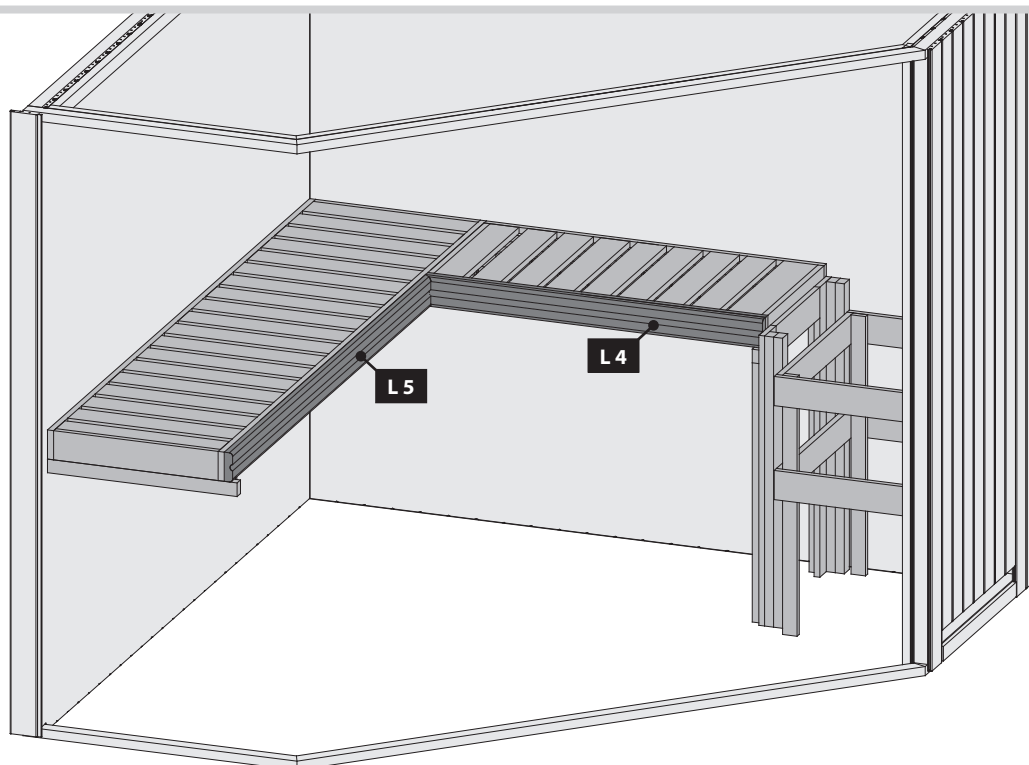

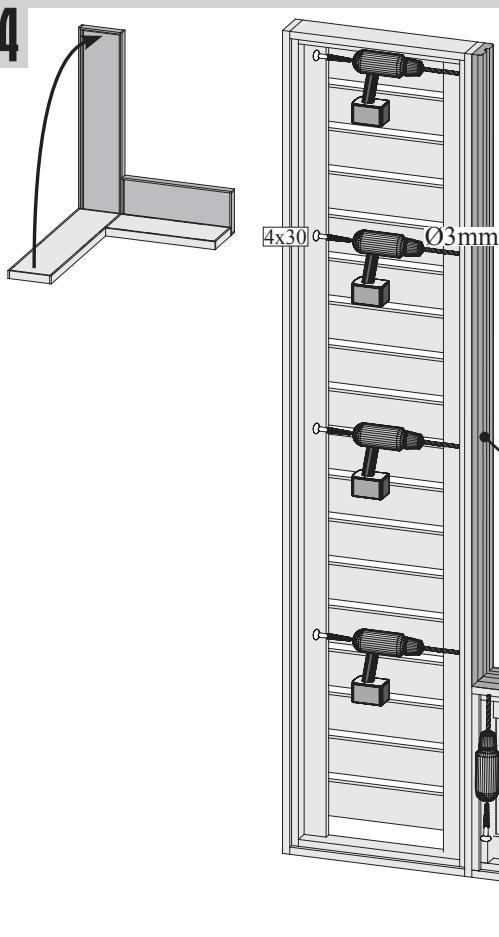
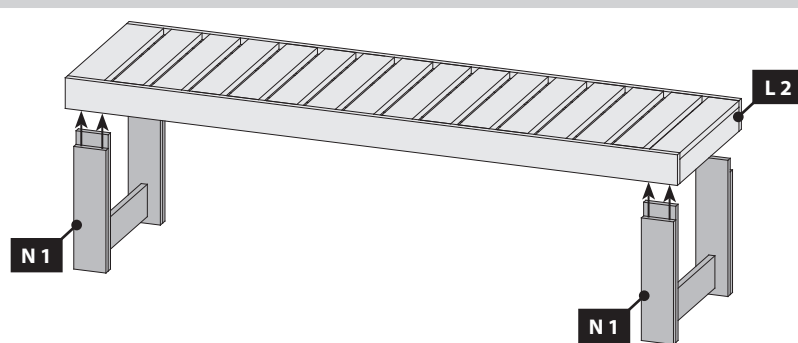
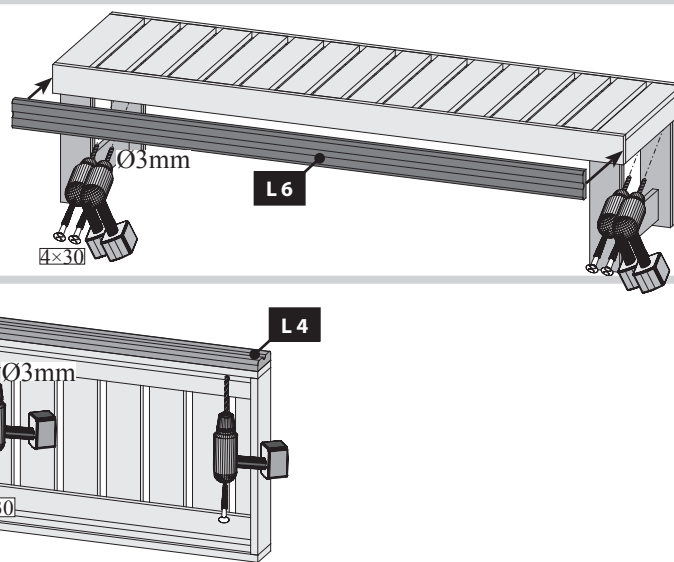
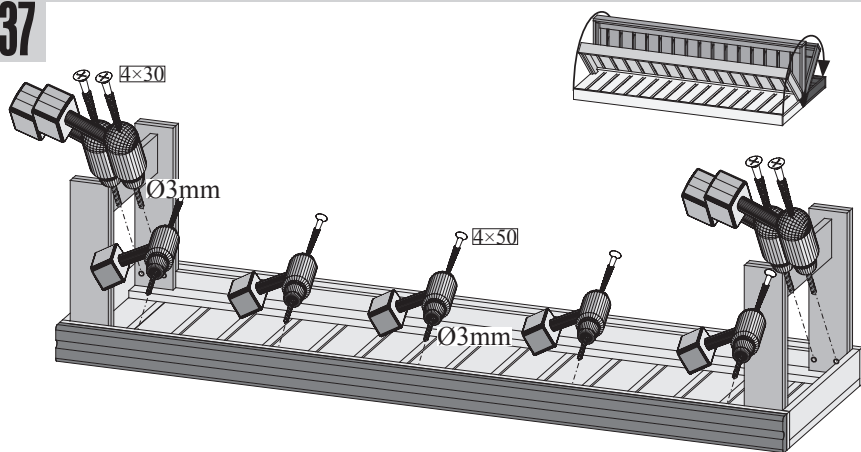
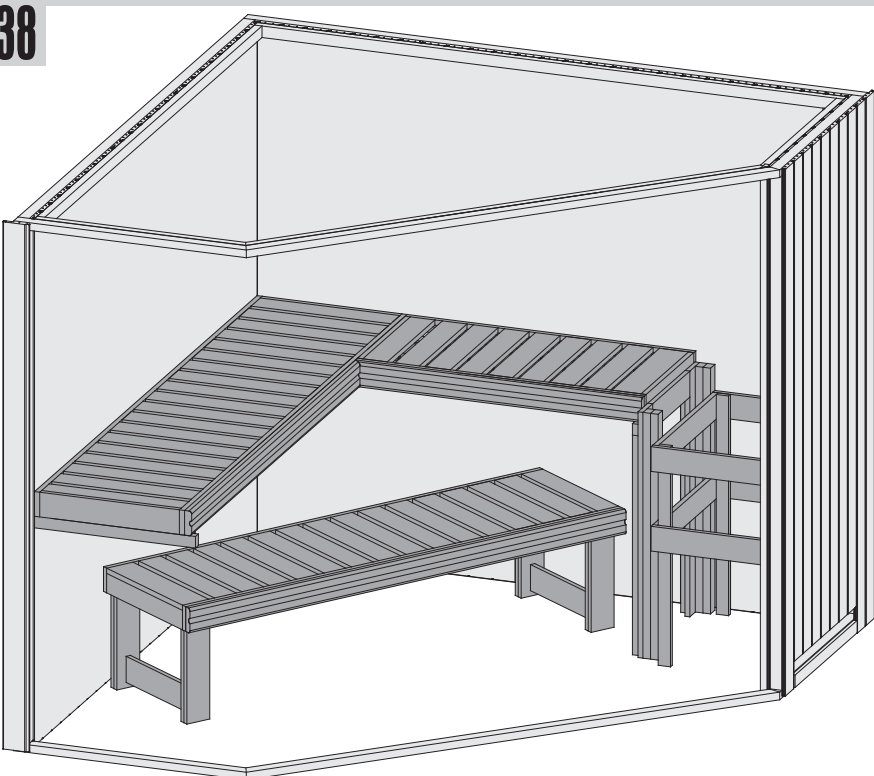
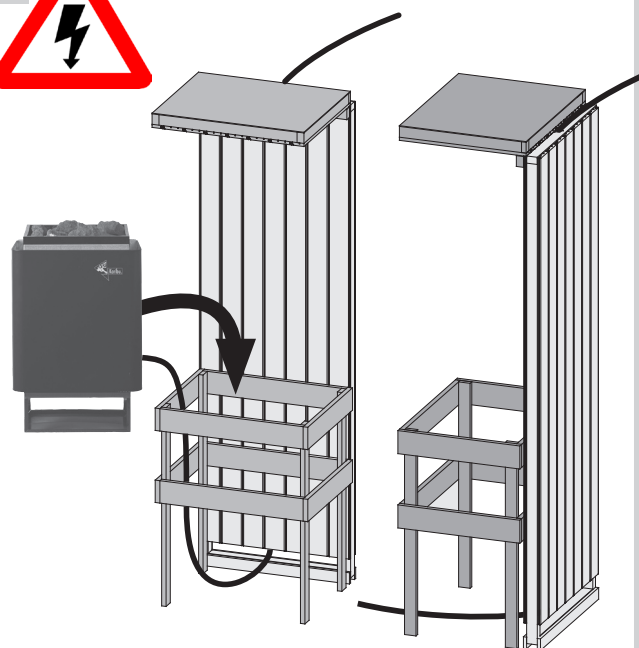
**34****35****36****37****38****39**

 Einbau Glastür

 Montage porte en verre

 Installation of glass door

 Montage van de glazen deur

 Montaje de la puerta de cristal

 Installazione portello di vetro



**04** — **08**





 Einbau Glastür

 Installation of glass door

 Montaje de la puerta de cristal

 Montage porte en verre

 Montage van de glazen deur

 Installazione portello di vetro

01

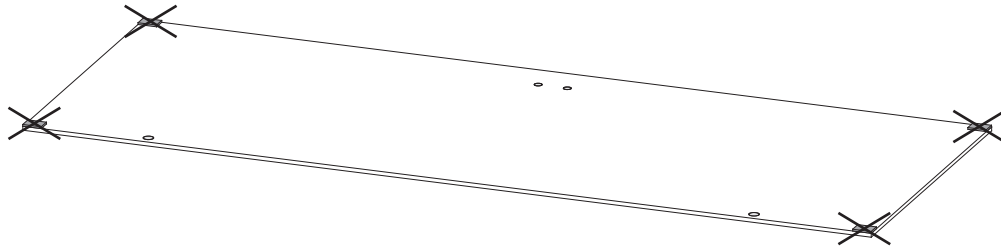

02

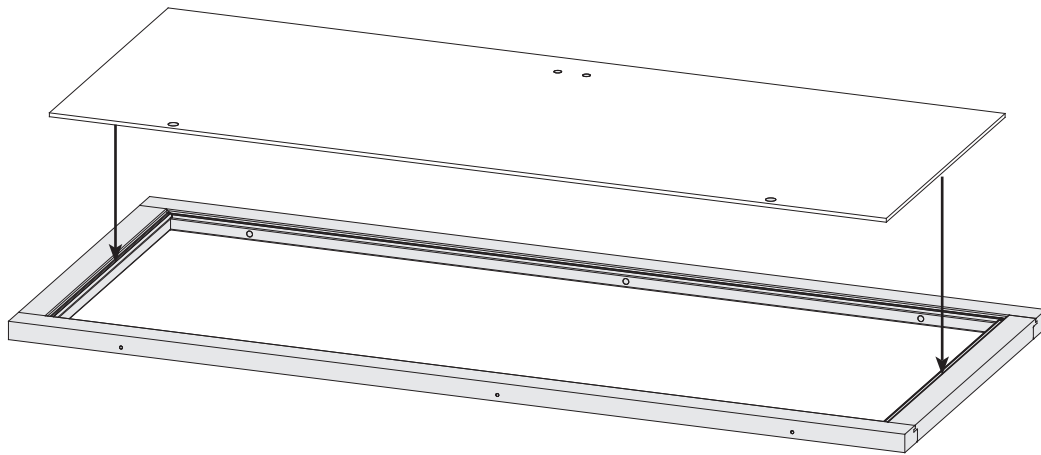



03

 Das Saunätürglas im Türrahmen ausrichten!

 Bien aligner le verre à vitre!

 To start building up the door you need to center the glass in the wooden frame!

 Plaats het glas van de sauna deur in het midden van het kozijn!

 ¡Centrar la puerta de cristal dentro del marco!

 Allineare il vetro dello sportello sauna al telaio della porta!

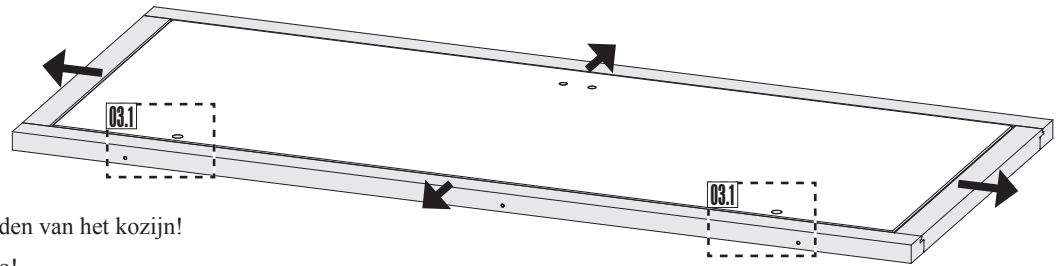

03.1-1

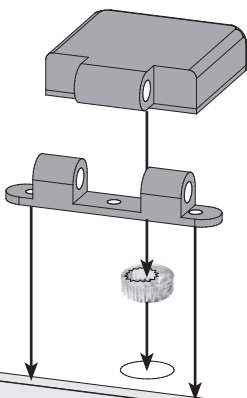

03.1-2

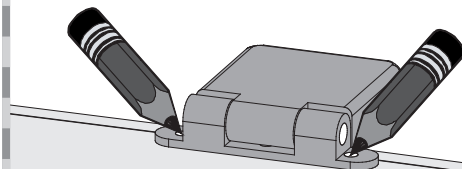

03.1-3

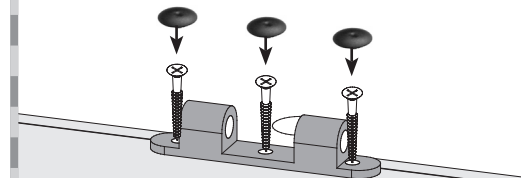

 Einbau Glastür

 Installation of glass door

 Montaje de la puerta de cristal

 Montage porte en verre

 Montage van de glazen deur

 Installazione portello di vetro

04

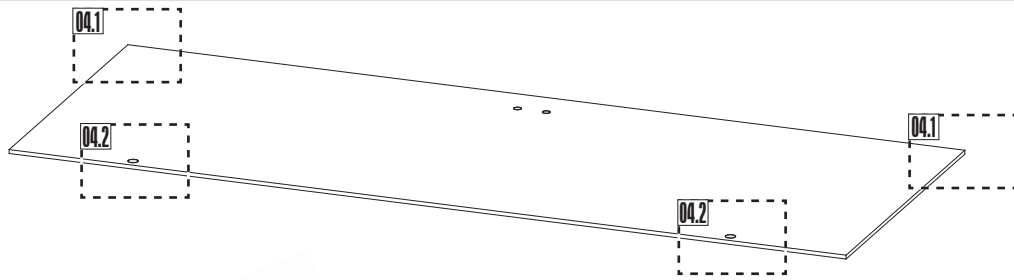

04.1-1

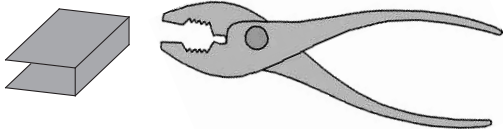

04.1-2

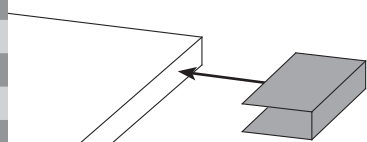

04.1-3

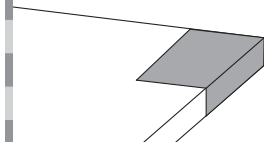

04.2-1

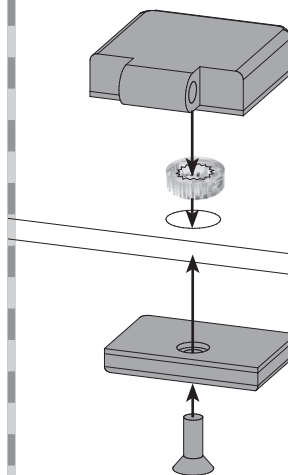

04.2-2

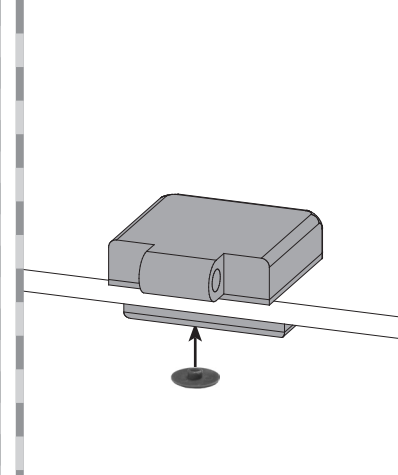

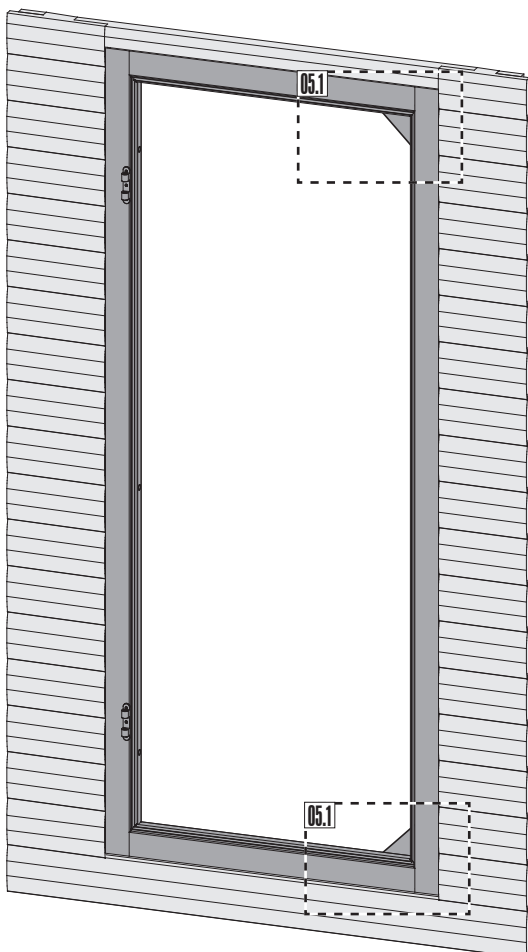

05





 Achtung: Alle Verstell-Excenter müssen in der Glasscheibe die gleiche Grundstellung haben!

 Attention: Tous les excentres de positionnement doivent avoir la même position de base dans la vitre!

 Attention: All adjustable eccentrics must have the same basic adjustment in the glass panel!

 Attentie: alle excentrische verstelelementen moeten in dezelfde stand in de glasplaat worden geplaatst!

 Atención: Todos los excéntricos regulables tienen que tener la misma posición base en la hoja de cristal.

 Attenzione: Tutti gli eccentrici di regolazione devono avere la stessa posizione base nella lastra di vetro!



05.1-1

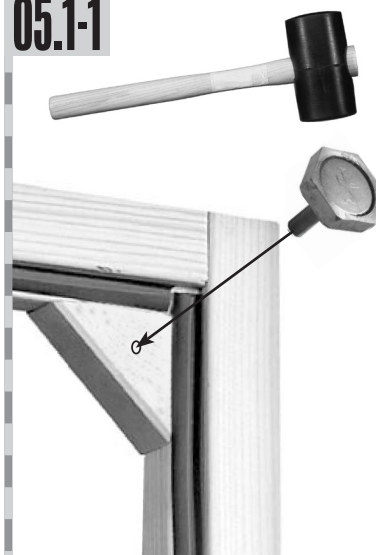

05.1-2





 Einbau Glastür

 Installation of glass door

 Montaje de la puerta de cristal

 Montage porte en verre

 Montage van de glazen deur

 Installazione portello di vetro

06

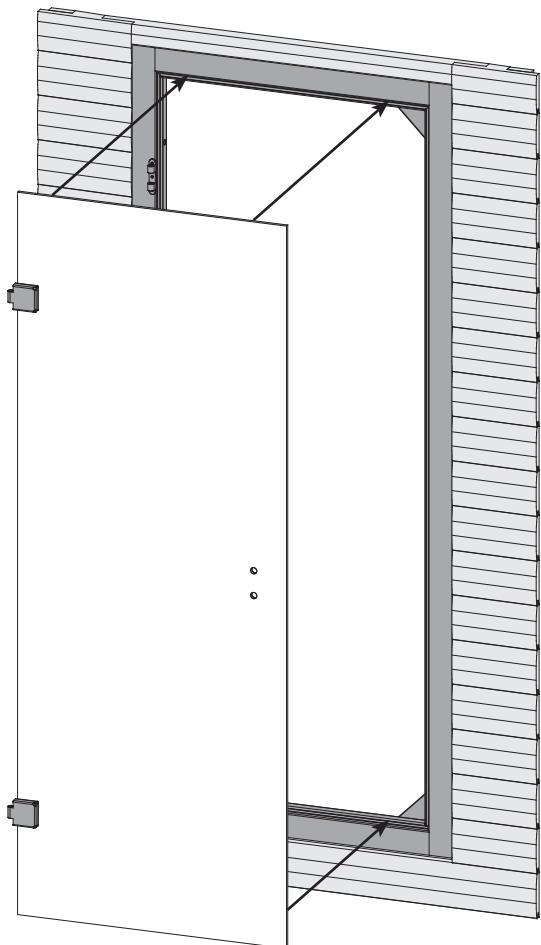

07

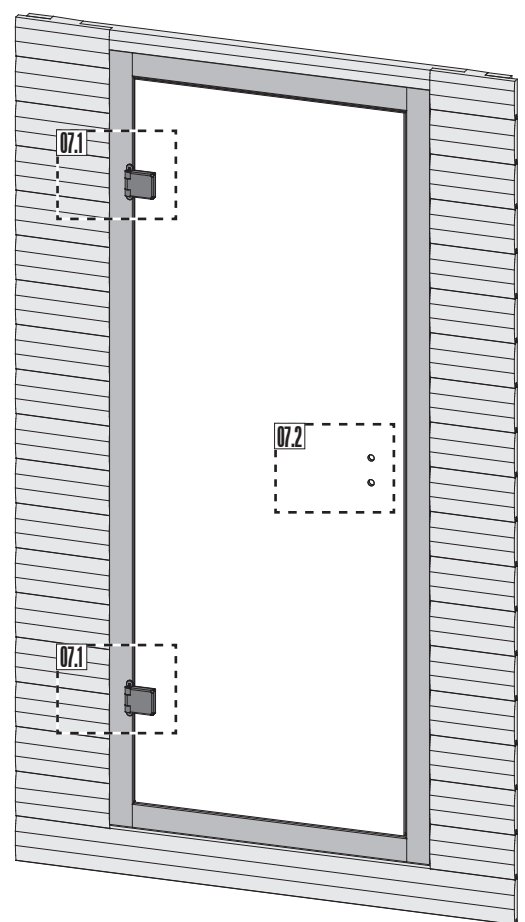

07.1

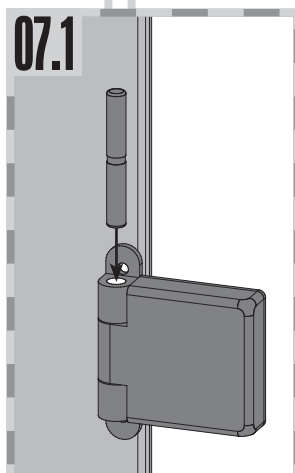

07.2-1

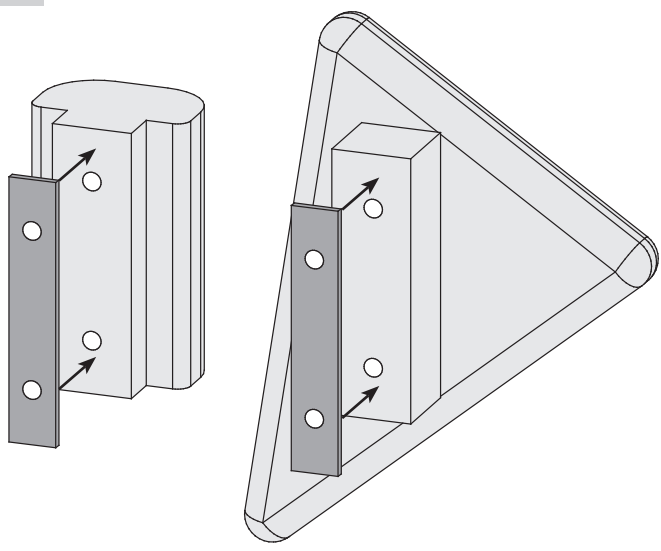

07.2-2

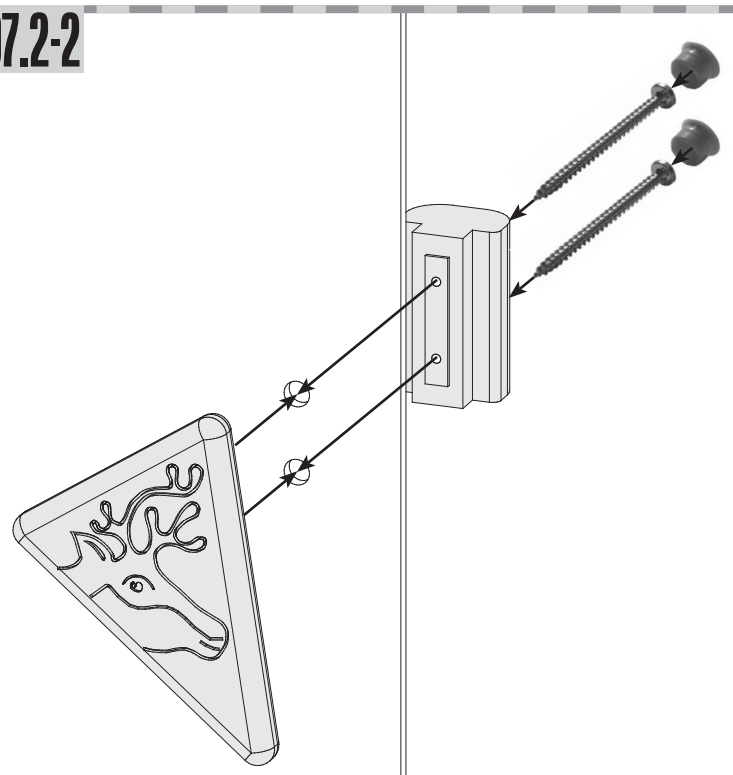

 **Seitenverstellung + Höhenverstellung**

Achtung: Alle Verstell-Excenter müssen in der Glasscheibe die gleiche Grundstellung haben!

 **Positionnement latéral + positionnement hauteur**

Attention: Tous les excentres de positionnement doivent avoir la même position de base dans la vitre!

 **Lateral adjustment + height adjustment**

Attention: All adjustable eccentrics must have the same basic adjustment in the glass panel!

 **Zijverstelling + hoogteverstelling**

Attentie: alle excentrische verstelelementen moeten in dezelfde stand in de glasplaat worden geplaatst!

 **Regulación lateral + regulación de la altura**

Atención: Todos los excéntricos regulables tienen que tener la misma posición base en la hoja de cristal.

 **Regolazione laterale + regolazione dell'altezza**

Attenzione: Tutti gli eccentrici di regolazione devono avere la stessa posizione base nella lastra di vetro!

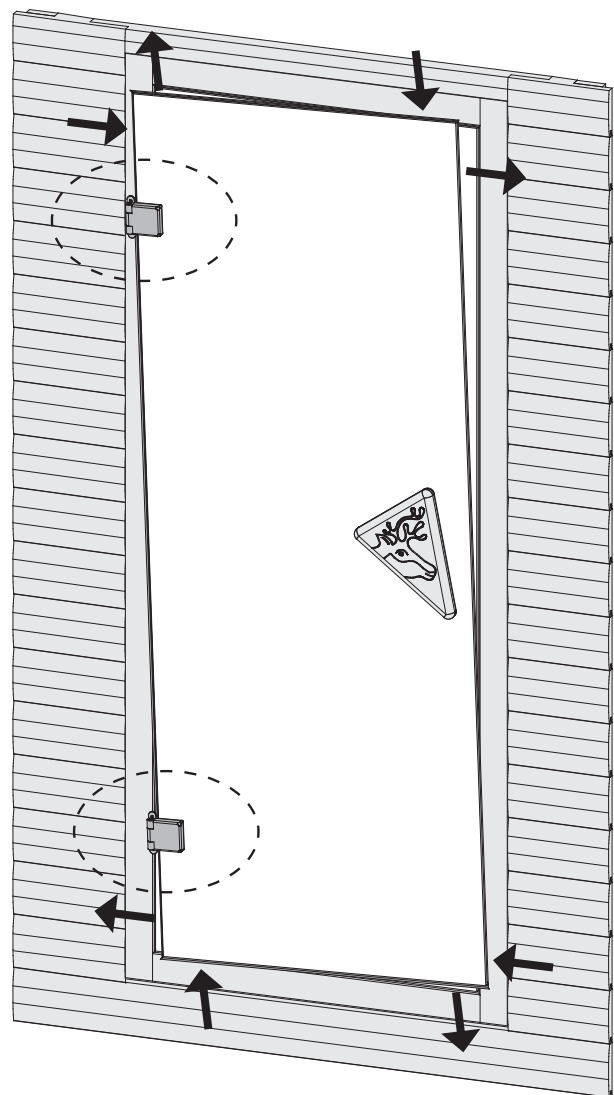
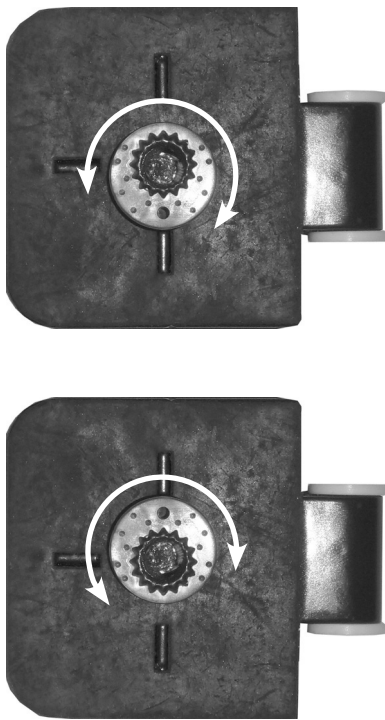

01

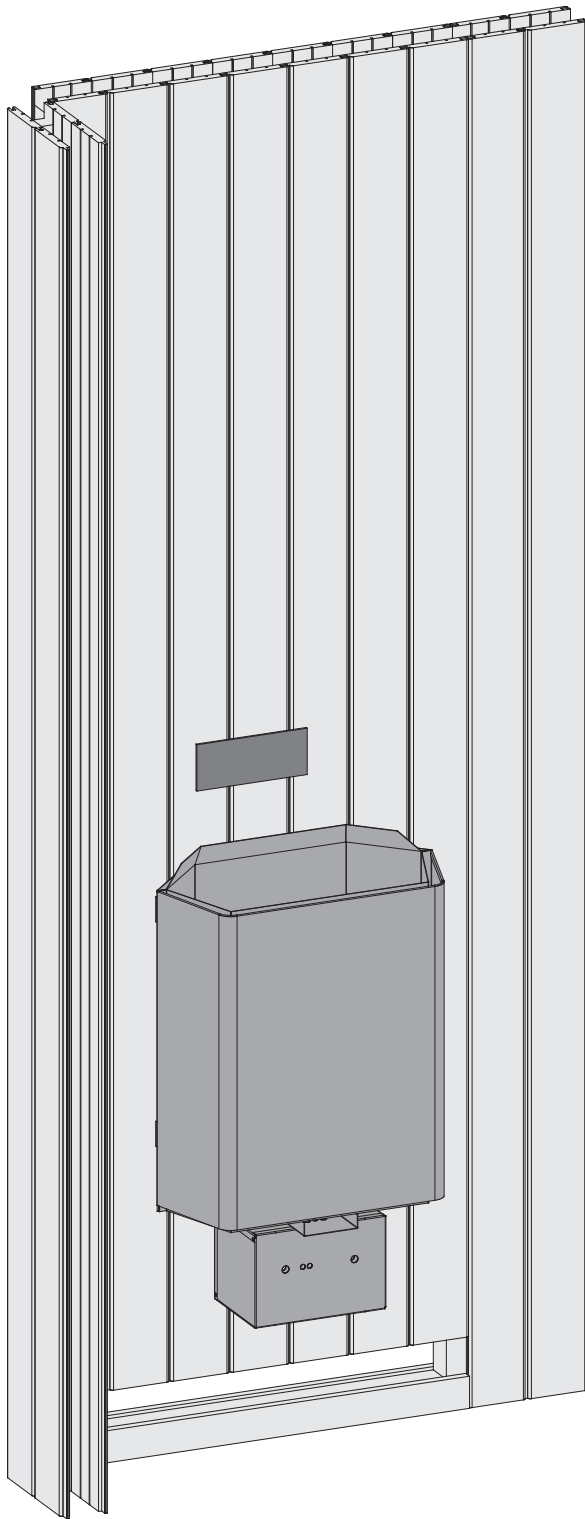

02

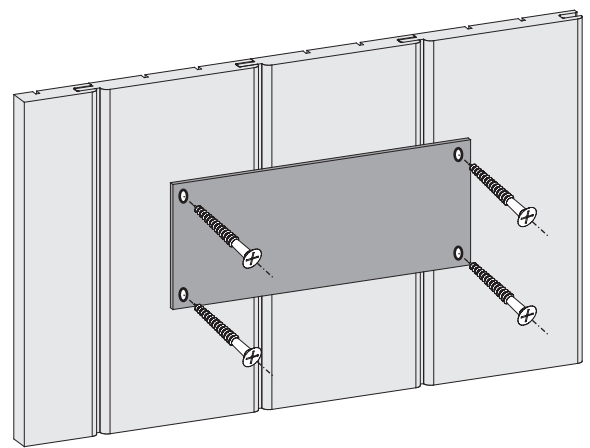

Entfernen Sie die Schutzfolie vom beiliegenden TÜV-Schild.

Lassen Sie den Saunaofen von einem zugelassenen Elektrofachmann anschließen. Dieser markiert den installierten Ofen auf dem TÜV-Schild.

Bringen Sie das TÜV-Schild an einer gut sichtbaren Stelle über dem Ofen an.

